

# Stepping Motors



Introduction		..... C-2	Introduction
<i>αSTEP</i>	AC Input	<b>AS</b> Series ..... C-14	<i>αSTEP</i> AS AC Input
	DC Input	<b>ASC</b> Series ..... C-62	<i>αSTEP</i> ASC DC Input
Stepping Motor and Driver Packages AC Input	Microstep	5-Phase Stepping Motor and Driver Package ..... C-90 <b>RK</b> Series	5-Phase Microstep RK AC Input
	Full/Half	2-Phase Stepping Motor and Driver Package ..... C-122 <b>UMK</b> Series	2-Phase Full/Half UMK
Stepping Motor and Driver Packages DC Input	Microstep	5-Phase Stepping Motor and Driver Package ..... C-134 <b>CRK</b> Series	5-Phase Microstep CRK
		2-Phase Stepping Motor and Driver Package ..... C-164 <b>RBK</b> Series	2-Phase Microstep RBK DC Input
		2-Phase Stepping Motor and Driver Package ..... C-180 <b>CMK</b> Series	2-Phase Microstep CMK
2-Phase Stepping Motors	Without Encoder	2-Phase Stepping Motors ..... C-205 <b>PK</b> Series/ <b>PV</b> Series	2-Phase PK/PV Without Encoder
	With Encoder	2-Phase Stepping Motors ..... C-261 <b>PK</b> Series	2-Phase PK With Encoder
Controllers..... C-269	<b>EMP400</b> Series..... C-274		<b>EMP400</b>
	<b>SG8030J</b> ..... C-289		<b>SG8030J</b>
Accessories		..... C-295	Accessories
Installation		..... C-319	Installation

# Overview of Stepping Motors

Stepping motors enable accurate positioning operation with ease.

They are used in various types of equipment for accurate rotation angle and speed control using pulse signals.

## Features

### Accurate Positioning in Fine Steps

A stepping motor rotates with a fixed step angle, just like the second hand of a clock. This angle is called "basic step angle." Oriental Motor offers 5-phase stepping motors with a basic step angle of  $0.72^\circ$  and 2-phase stepping motors with a basic step angle of  $1.8^\circ$ .

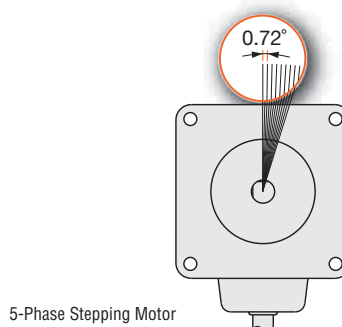

5-Phase Stepping Motor

### Easy Control with Pulse Signals

A system configuration for high accuracy positioning is shown below. The rotation angle and speed of the stepping motor can be controlled accurately using pulse signals from the controller.

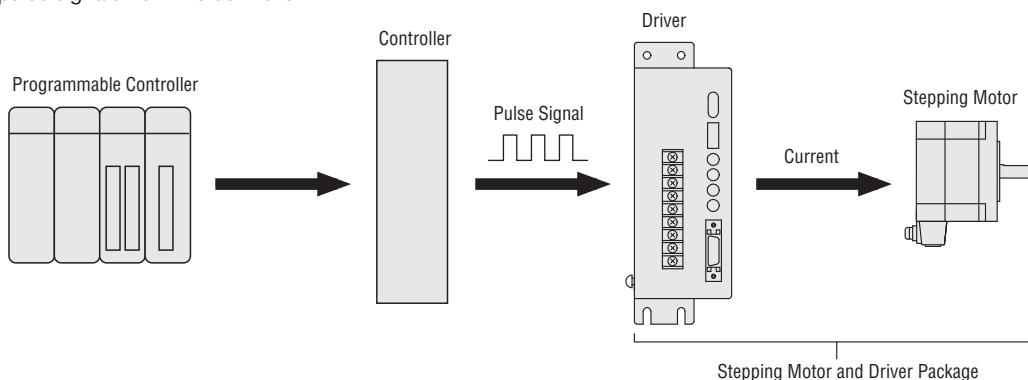

### What is a Pulse Signal?

A pulse signal is an electrical signal whose voltage level changes repeatedly between ON and OFF.

Each ON/OFF cycle is counted as one pulse. A command with one pulse causes the motor output shaft to turn by one step.

The signal levels corresponding to voltage ON and OFF conditions are referred to as "H" and "L," respectively.

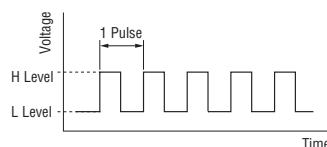

### The Amount of Rotation is Proportional to the Number of Pulses

The amount of rotation of the stepping motor is proportional to the number of pulse signal (pulse number) given to the driver.

The relationship of the stepping motor's rotation (rotation angle of the motor output shaft) and pulse number is expressed as follows:

$$\theta = \theta_s \times A$$

$\theta$  : Rotation angle of the motor output shaft [deg]  
 $\theta_s$  : Step angle [deg/step]  
 $A$  : Pulse number [pulses]

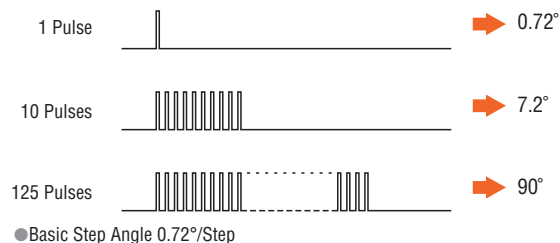

### The Speed is Proportional to the Pulse Speed

The speed of the stepping motor is proportional to the speed of pulse signals (pulse frequency) given to the driver.

The relationship of the pulse speed [Hz] and motor speed [r/min] is expressed as follows:

$$N = \frac{\theta_s}{360} \times f \times 60$$

$N$  : Speed of the motor output shaft [r/min]  
 $\theta_s$  : Step angle [deg/step]  
 $f$  : Pulse speed [Hz]  
 (Number of pulses input per second)

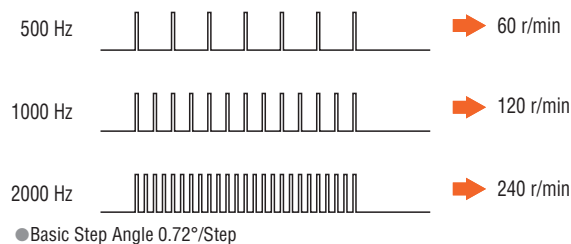

● **Generating High Torque with a Compact Body**

Stepping motors generate high torque with a compact body. These features give them excellent acceleration and response, which in turn makes these motors well-suited for torque-demanding applications where the motor must be started and stopped frequently. To meet the need for greater torque at low speed, Oriental Motor also has geared motors combining compact design and high torque.

◇ **Frequent Starting/Stopping is Possible**

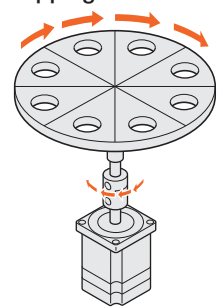

◇ **Speed – Torque Characteristics [Motor frame size 60 mm (2.36 in.)]**

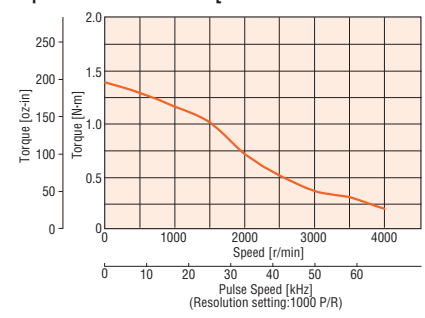

● **The Motor Holds Itself at a Stopped Position**

Stepping motors continue to generate holding torque even at standstill. This means that the motor can be held at a stopped position without using a mechanical brake.

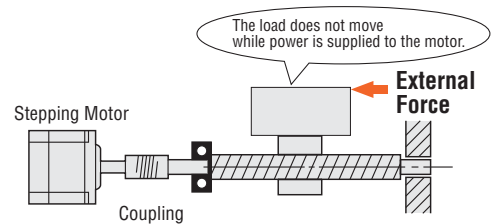

Once the power is cut off, the self-holding torque of the motor is lost and the motor can no longer be held at the stopped position in vertical operations or when an external force is applied. In lift and similar applications, use an electromagnetic brake type.

◇ **Electromagnetic Brake Type**

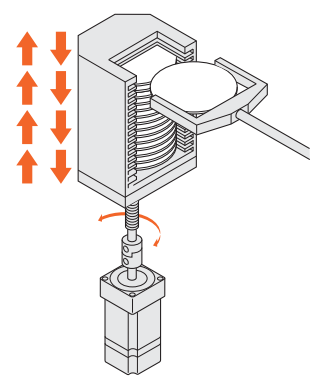

● **Closed Loop Stepping Motor and Driver Package  $\alpha$ STEP**

The  $\alpha$ STEP consists of package products designed to draw out the maximum features of a stepping motor. These packages normally operate synchronously with pulse commands, but when a sudden acceleration or load change occurs, a unique control mode maintains the positioning operation.  $\alpha$ STEP models can also output positioning completion and alarm signals, which increases the reliability of the equipment in which they operate.

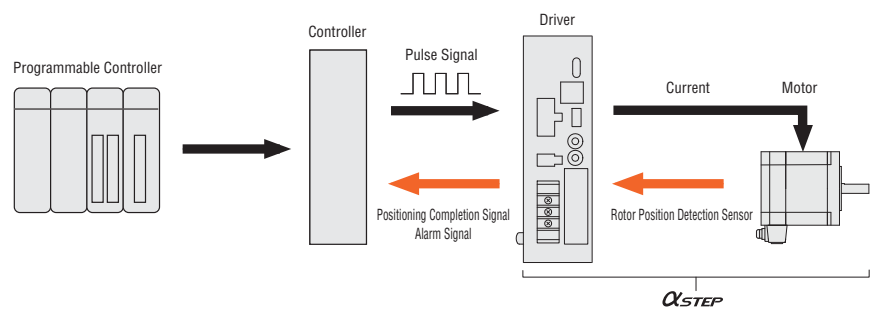

Introduction

$\alpha$ STEP AS AC Input

$\alpha$ STEP AS DC Input

5-Phase Microstep RK AC Input

2-Phase Full/Half UMK AC Input

5-Phase Microstep CMK DC Input

2-Phase Microstep RBK DC Input

2-Phase Microstep CMK DC Input

2-Phase PK/PV Without Encoder

2-Phase PK With Encoder

EMP400 Controllers

SG8030J

Accessories

Installation

## Motor Types

Stepping motors come in different types including the standard type, electromagnetic brake type, and various geared types. The availability of such a wide selection means, that you can choose an optimal type according to the function and performance required in your specific application. Using the ***αSTEP AS*** Series as an example, the different types of motors will be described more completely. For details on the types available with other series, check the pages on which each product is listed.

### Standard Type

A basic model that is easy to use and designed with a balanced set of functions and characteristics.

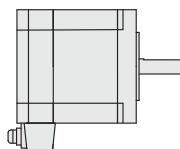

### Standard Type Industrial Connector

These motors conform to the IP65 rating, for protection against dust and water ingress.

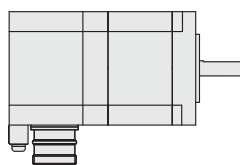

### Electromagnetic Brake Type

These motors incorporate a non-excitation type electromagnetic brake. When the power is accidentally cut off due to power outage or other unexpected event, the electromagnetic brake holds the load in position to prevent it from dropping or moving.

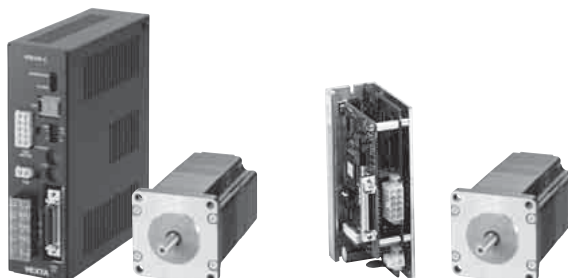
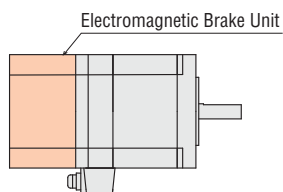

### Geared Type

These motors incorporate a dedicated position-control gearhead with reduced backlash to make the most of the high controllability of the motors.

The gearhead ensures highly accurate, smooth operation even in applications where a large torque is received.

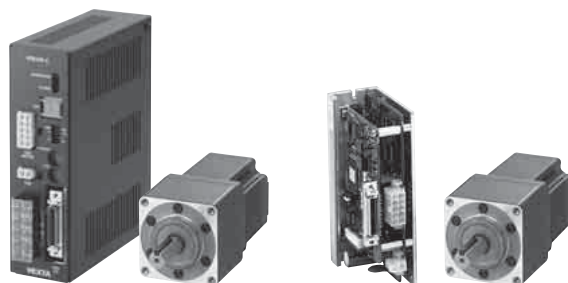
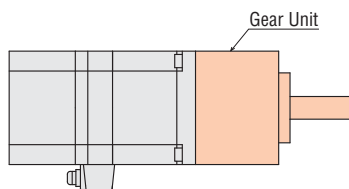

### Characteristics Comparison for *αSTEP AS* Series Geared Motors

Geared Type	Permissible Torque [N·m (lb-in)]	Backlash [arc min]	Resolution [deg/step]	Speed [r/min]
<b>TH</b> Geared	12 (106)	45	0.012	500
<b>PN</b> Geared	37 (320)	3	0.0072	600
Harmonic Geared	37 (320)	0	0.0036	70

● Values shown above are representative values. They vary depending on the products.

## Types of Operation Systems

Each stepping motor and driver package combines a stepping motor selected from various types, with a dedicated driver. Drivers that operate in the pulse input mode and built-in controller mode are available. You can select a desired combination according to the required operation system. Different drivers are explained below by using the **αSTEP AS** Series as an example.

### Pulse Input Package

The motor can be controlled using a pulse generator provided by the user. Operation data is input to the pulse generator beforehand, and you select the operation data on the host programmable controller, then input the operation command.

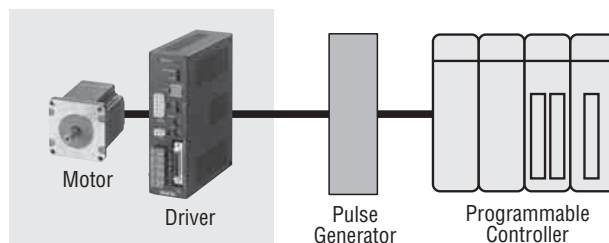

### Built-In Controller Package

The built-in pulse generation function allows the motor to be driven via a directly connected personal computer or programmable controller. Since no separate pulse generator is required, the drivers of this type save space and simplify wiring.

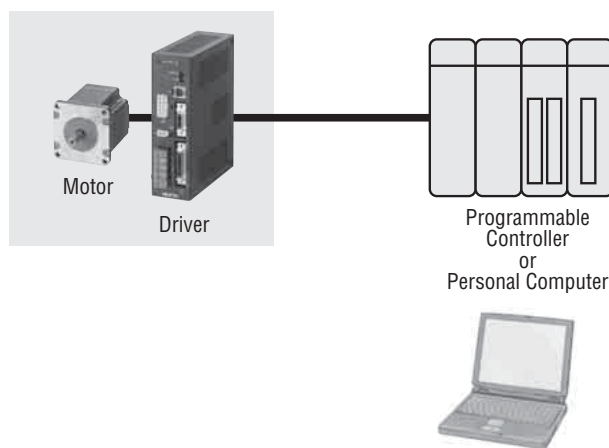









## Types of Stepping Motors

One feature of stepping motors is that they can perform accurate positioning operation with ease.

So that more users can enjoy the benefits of stepping motors, Oriental Motor has many different product series designed with different power supply specifications and offering different functions. There is also a wide spectrum of variations within each series, as models come in different frame sizes and with/without an electromagnetic brake and different gear types.

### AC Input Type









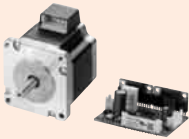

Power Supply Input	AC Input			
	Single-Phase 100-115 VAC, Single-Phase 200-230 VAC, Three-Phase 200-230 VAC		Single-Phase 100-115 VAC, Single-Phase 200-230 VAC	Single-Phase 100/115 VAC
Series	<i>α</i> STEP AS Series		RK Series	UMK Series
	Pulse Input Package	Built-In Controller Package		
Features				
	<ul style="list-style-type: none"> <li>● Closed loop control</li> <li>● High response</li> <li>● No hunting</li> <li>● Low vibration</li> </ul>		<ul style="list-style-type: none"> <li>● Closed loop control</li> <li>● High response</li> <li>● No hunting</li> <li>● Low vibration</li> <li>● Space-saving, simple wiring</li> </ul>	<ul style="list-style-type: none"> <li>● Low vibration, low noise due to smooth drive function</li> <li>● High-resolution control is possible by microstepping</li> </ul>
Motor Type	Closed loop control stepping motor		5-phase stepping motor	2-phase stepping motor
Basic Step Angle	0.36° (Resolution setting: 1000 P/R)		0.72°	1.8°
Resolution	Microstep 0.72°, 0.36°, 0.072°, 0.036°		Microstep 0.72° ~ 0.00288° (16 steps)	Full step/half step 1.8°/0.9°
Functions	Resolution Select	●	●	●
	Pulse Input Mode Switch	●	—	●
	Automatic Current Cutback	●	●	●
	Current Setting	●	●	●
	Step Angle Select Input	●	—	●
	Velocity Filter	●	●	—
	All Windings Off Input	●	●	●
	Timing Output	●	—	●
	Built-In Controller	—	●	—
	Smooth Drive	—	—	●
	Input Power Supply Voltage Switch	—	—	—
Protective Functions	Overcurrent/Overheat Overload/Overvoltage		Overheat output	Overheat output
Safety Standards	c 		c 	
RoHS Compliant				
Lineup	Standard Motor	mm (in.) □42, 60, 85 (□1.65, 2.36, 3.35)	□42, 60, 85 (□1.65, 2.36, 3.35)	□42, 60, 85 (□1.65, 2.36, 3.35)
	Standard Type Industrial Connector Standard Type Terminal Box	mm (in.) □60, 85 (□2.36, 3.35)	—	□60, 85 (□2.36, 3.35)
	Electromagnetic Brake Motor	mm (in.) □42, 60, 85 (□1.65, 2.36, 3.35)	□42, 60, 85 (□1.65, 2.36, 3.35)	—
	G geared Motor	mm (in.) □42, 60, 90 (□1.65, 2.36, 3.54)	□42, 60, 90 (□1.65, 2.36, 3.54)	□42, 60, 90 (□1.65, 2.36, 3.54)
Page	Page C-14		Page C-90	Page C-122

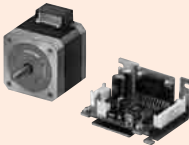
### Stepping Motor

A wide range of motors ideal for different motor sizes and equipment specifications can be purchased individually.

2-phase stepping motors → Page C-205

## ● DC Input Type

Power Supply Input		DC Input			
		24 VDC	24 VDC	24-75 VDC	24 VDC
Series		<i>α</i> STEP ASC Series	CRK Series	RBK Series	CMK Series
Features					
		<ul style="list-style-type: none"> <li>● Closed loop control</li> <li>● High response</li> <li>● No hunting</li> <li>● Low vibration</li> </ul>	<ul style="list-style-type: none"> <li>● Low vibration, low noise due to smooth drive function</li> <li>● Wide variety of high-resolution types and geared motors</li> </ul>	<ul style="list-style-type: none"> <li>● 2-phase stepping motor and compact DC input driver in one package</li> <li>● High-resolution control is possible by microstepping</li> <li>● Low vibration, low noise due to smooth drive function</li> </ul>	<ul style="list-style-type: none"> <li>● 2-phase stepping motor and compact DC input driver in one package</li> <li>● High-resolution control is possible by microstepping</li> </ul>
Motor Type		Closed loop control stepping motor	5-phase stepping motor	2-phase stepping motor	2-phase stepping motor
Basic Step Angle		0.36°(Resolution setting: 1000 P/R)	0.72°, 0.36°(High-resolution type)	1.8°	1.8°, 0.9°(High-resolution type)
Resolution		Microstep 0.72°, 0.36°, 0.072°, 0.036°	Microstep 1.8°~0.00288°(25 steps)	Microstep 1.8°~0.0140625°(16 steps)	Microstep 1.8°~0.1125°(5 steps)
Functions	Resolution Select	●	●	●	●
	Pulse Input Mode Switch	●	●	—	●
	Automatic Current Cutback	●	●	●	●
	Current Setting	●	●	●	●
	Step Angle Select Input	●	●	●	●
	Velocity Filter	●	—	—	—
	All Windings Off Input	●	●	●	●
	Timing Output	●	●	●	●
	Built-In Controller	—	—	—	—
	Smooth Drive	—	●	●	—
	Input Power Supply Voltage Switch	—	—	—	—
	Protective Functions	Overload/ Overvoltage	—	Overcurrent/Overload Overvoltage	—
Safety Standards					—
RoHS Compliant					
Lineup	Standard Motor	mm (in.) □28, 42, 60 (□1.10, 1.65, 2.36)	□20, 28, 42, 60 (□0.79, 1.10, 1.65, 2.36)	□60, 85 (□2.36, 3.35)	□28, 35, 42, 50, 56.4, 60 (□1.10, 1.38, 1.65, 1.97, 2.22, 2.36)
	Standard Type Terminal Box	mm (in.) —	—	□60, 85 (□2.36, 3.35)	—
	Electromagnetic Brake Motor	mm (in.) □42, 60 (□1.65, 2.36)	—	—	—
	Geared Motor	mm (in.) □28, 42, 60 (□1.10, 1.65, 2.36)	□20, 28, 42, 60 (□0.79, 1.10, 1.65, 2.36)	—	□28, 42, 60 (□1.10, 1.65, 2.36)
Page		Page C-62	Page C-134	Page C-164	Page C-180

\* Only for terminal box type

Introduction

AC Input  
*α*STEP  
ASDC Input  
*α*STEP  
ASC5-Phase  
Microstep  
RKAC Input  
2-Phase  
Full/Half  
UMK5-Phase  
Microstep  
CRKDC Input  
2-Phase  
Microstep  
RBK2-Phase  
Microstep  
CMKWithout Encoder  
2-Phase  
PK/PVWith Encoder  
2-Phase  
PK

EMP400

Controllers  
SG8030J



Accessories

Installation

## Introduction of Geared Type ( $\alpha_{STEP}$ , Stepping Motors)

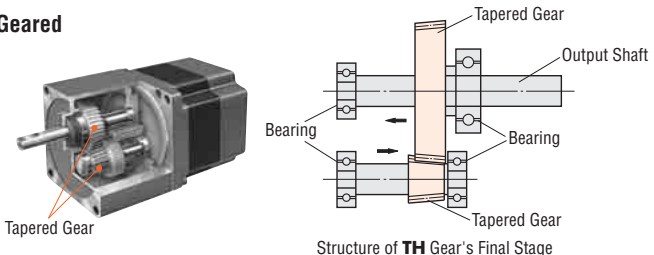
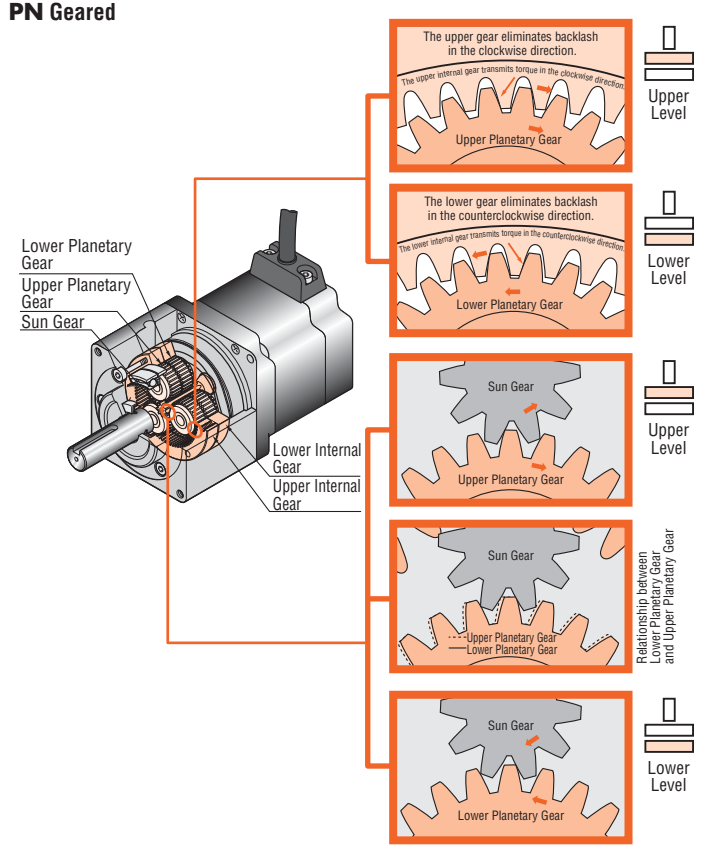
Geared Motors using dedicated gears for control motors.

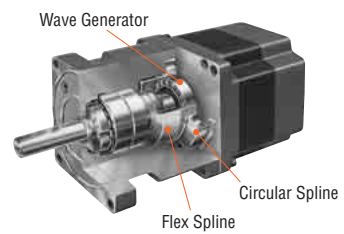
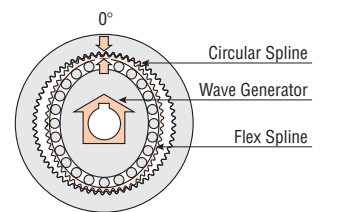
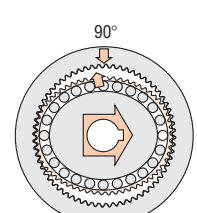
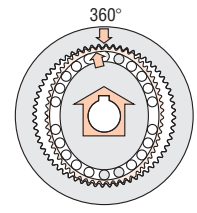
	Type	Principle and Structure	Series
Low backlash	<p><b>TH Geared</b></p>  <p>The diagram shows a cutaway view of a TH Geared motor on the left, highlighting a tapered gear. To the right, a detailed cross-section of the final gear stage is shown, featuring a tapered gear mounted on an output shaft, supported by bearings. Arrows indicate the adjustment of the tapered gear's profile to reduce backlash.</p> <p>Structure of TH Gear's Final Stage</p>	<p>With the <b>TH</b> geared type, tapered gears are used for the spur gear's speed-reduction mechanism and the meshing gear. The tapered gear is produced through continuous profile shifting toward the shaft. The tapered gears are adjusted in the direction of the arrows, as shown in the figure, to reduce backlash.</p>	<p><b>AS</b> Series <b>ASC</b> Series <b>RK</b> Series <b>CRK</b> Series</p>
Non-backlash	<p><b>PN Geared</b></p>  <p>The diagram shows a cutaway view of a PN Geared motor on the left, with labels for Lower Planetary Gear, Upper Planetary Gear, Sun Gear, Lower Internal Gear, and Upper Internal Gear. To the right, five detailed cross-sections illustrate the gear meshing at different levels. The top two sections show the Upper Level with an Upper Planetary Gear and an Upper Internal Gear. The bottom three sections show the Lower Level with a Lower Planetary Gear and a Lower Internal Gear. A central Sun Gear is shown meshing with both levels. Text boxes explain how the upper gear eliminates backlash in the clockwise direction and the lower gear eliminates backlash in the counterclockwise direction. A legend indicates the relationship between the Lower Planetary Gear and the Upper Planetary Gear.</p>	<p>The <b>PN</b> gear employs a planetary gear speed-reduction mechanism. The <b>PN</b> gear achieves the specified backlash of three arc minutes through the improved accuracy of its components and the backlash-elimination mechanism. That mechanism is comprised of two sets of internal and planetary gears on the upper and lower levels with the internal gear teeth twisted in the circumferential direction. The upper-level internal gears and planetary gears reduce clockwise backlash; the lower-level internal gears and planetary gear reduce counterclockwise backlash.</p>	<p><b>AS</b> Series <b>ASC</b> Series <b>RK</b> Series <b>CRK</b> Series</p>

	Type	Principle and Structure	Series
<p>Non-backlash</p>	<p><b>Harmonic Geared</b></p>   <p>Combines three basic parts. The flex spline is bent into an oval shape by the wave generator. The teeth at the long axis of the oval mesh with the circular spline, while the teeth at the short axis of the oval are completely separate from it.</p>  <p>Rotating the wave generator (input) clockwise while keeping the circular spline fixed in position will subject the flex spline to elastic deformation, causing a gradual shift in the point of engagement between the circular spline and flex spline.</p>  <p>When the wave generator completes one revolution, the flex spline has rotated two fewer teeth than the circular spline has, resulting in the movement of flex spline for the difference in the tooth count (two teeth) in the opposite direction of the wave generator's rotation (i.e., counterclockwise). This movement translates into output, thereby reducing the speed.</p>	<p>The harmonic gear offers unparalleled precision in positioning and features a simple construction utilizing the metal's elastomechanical property, comprising just three basic components: a wave generator, flex spline and circular spline.</p>	<p><b>AS Series</b> <b>ASC Series</b> <b>RK Series</b> <b>CRK Series</b></p>
<p>For 2-phase stepping motors</p>	<p><b>SH Geared</b></p> 	<p><b>SH</b> geared type is for stepping motors with spur gear's speed reduction mechanism. Backlash value is 1° to 2°.</p>	<p><b>CMK Series</b> 2-Phase <b>PK Series</b></p>





## ● Characteristics Comparison for Geared Motors

### Notes:

- Note that the values shown below must be used as reference. These values vary depending on the series, frame size and gear ratio.
- Maximum torque, permissible torque, backlash, minimum resolution and maximum output shaft speed listed here are representative values of the following series:

**TH** Geared Type, **PN** Geared Type, Harmonic Geared Type: **αSTEP AS** Series

**SH** Geared Type: **CMK** Series

Geared Type	Features	Maximum and Permissible Torque [N·m (lb-in)]	Backlash [arc min] (Reference value)	Minimum Resolution [deg/step]	Maximum Output Shaft Speed [r/min]
Low backlash  <b>TH</b> Geared (Parallel shaft)	<ul style="list-style-type: none"> <li>• A wide variety of low gear ratios, high-speed operation</li> <li>• Gear ratios: 3.6:1, 7.2:1, 10:1, 20:1, 30:1</li> </ul>	12 (106)	45	0.012	500
Non-backlash  <b>PN</b> Geared (Planetary)	<ul style="list-style-type: none"> <li>• High speed (low gear ratio), high accuracy positioning</li> <li>• High permissible/maximum torque</li> <li>• A wide variety of gear ratios for selecting the desired step angle. (resolution)</li> <li>• Centered output shaft</li> <li>• Gear ratios: 5:1, 7.2:1, 10:1, 25:1, 36:1, 50:1</li> </ul>	Maximum Torque 60 (530)  Permissible Torque 37 (320)	3	0.0072	600
 Harmonic Geared (Harmonic drive)	<ul style="list-style-type: none"> <li>• High accuracy positioning</li> <li>• High permissible/maximum torque</li> <li>• High gear ratios, high resolution</li> <li>• Centered output shaft</li> <li>• Gear ratios: 50:1, 100:1</li> </ul>	Maximum Torque 55 (480)  Permissible Torque 37 (320)	0	0.0036	70
For 2-phase stepping motors  <b>SH</b> Geared (Parallel shaft)	<ul style="list-style-type: none"> <li>• A wide variety of low gear ratios, high-speed operation</li> <li>• Gear ratios: 3.6:1, 7.2:1, 9:1, 10:1, 18:1, 36:1</li> </ul>	4 (35)	Approx. 1°~2°	0.05	500

# How to Read Specifications Table

Model	Single-Phase 100-115 VAC	Single Shaft	<b>RK566AAE</b>	<b>RK566AAE-N5</b>
		Double Shaft	<b>RK566BAE</b>	<b>RK566BAE-N5</b>
①	Single-Phase 200-230 VAC	Single Shaft	<b>RK566ACE</b>	<b>RK566ACE-N5</b>
		Double Shaft	<b>RK566BCE</b>	<b>RK566BCE-N5</b>
①	Maximum Holding Torque	N·m (oz·in)	0.83 (117)	3.5 (30 lb·in)
②	Rotor Inertia J	kg·m <sup>2</sup> (oz·in <sup>2</sup> )	280×10 <sup>-7</sup> (1.53)	280×10 <sup>-7</sup> (1.53)
③	Rated Current	A/Phase	1.4	
④	Basic Step Angle		0.72°	0.144°
⑤	Gear Ratio		—	1:5
⑥	Permissible Torque	N·m (lb·in)	—	3.5 (30)
⑦	Maximum Torque	N·m (lb·in)	—	7 (61)
⑧	Backlash	arc minute (degrees)	—	2 (0.034°)
⑨	Angular Transmission Error	arc minute (degrees)	—	5 (0.084°)
⑩	Permissible Speed Range	r/min	—	0~600
⑪	Power Source		Single-Phase 100-115 VAC+15% 50/60 Hz 4.5 A Single-Phase 200-230 VAC+15% 50/60 Hz 3.5 A	
⑫	Excitation Mode		Microstep	
Mass	Motor	kg (lb.)	0.8 (1.8)	1.5 (3.3)
	Driver	kg (lb.)	0.85 (1.9)	
Dimension No.	Motor		②	⑥
	Driver		②	

## ① Maximum Holding Torque

The holding torque (5-phase: 5-phase excitation, 2-phase: 2-phase excitation) is the maximum holding power (torque) the stepping motor has when power (rated current) is being supplied but the motor is not rotating (with consideration given to the permissible strength of the gear when applicable). At motor standstill, the driver's automatic current cutback function reduces the maximum holding torque by approximately 50% (approximately 40% for **UMK** and **CMK** Series).

## ② Rotor Inertia

This refers to the inertia of rotor inside the motor. This is necessary when the required torque (acceleration torque) for the motor needs is calculated.

## ③ Rated Current

The rated current is determined by motor temperature rise. It is the current value that can flow to the motor coils continuously at motor standstill. As a general rule, the current must be set to the rated current.

## ④ Basic Step Angle

The step angle is the angular distance (in degrees) that the motor moves at the input of one pulse from the driver. It differs depending on the motor structure and excitation mode.

## ⑤ Gear Ratio

This is the ratio in rotation speed between the input speed from the motor and the speed of the gear output shaft. For example, the gear ratio 10:1 is that when the input speed from the motor is 10 r/min, the gear output shaft is 1 r/min.

## ⑥ Permissible Torque

The permissible torque represents the torque value limited by the mechanical strength of the gear when operated at a constant speed. For the types excluding **PN** and harmonic geared types, the total torque including acceleration/deceleration torque should not exceed this value.

## ⑦ Maximum Torque (PN geared, harmonic geared type only)

This is the maximum torque that can be used instantaneously (for a short time). During acceleration/deceleration, the motor can be operated up to this value.

## ⑧ Backlash

The play of gear output shaft when the motor shaft is fixed. When positioning in bi-direction, the positioning accuracy is affected.

## ⑨ Angular Transmission Error (PN geared type only)

Angular transmission error is the difference between the theoretical angle of rotation of the output shaft, as calculated from the input pulse count, and actual angle of rotation.

## ⑩ Permissible Speed Range

This is the rotation speed that the motor can be operated at with the gear output shaft.

## ⑪ Power Source

The current value of the power input is the maximum input current value. (The input current varies according to the rotation speed.)

## ⑫ Excitation Mode

The driver has a function that can change the motor's step angle. Shown in the table is the step angle value at which the motor can be operated. (For the step angle value of microstep, see "Connection and Operation.")

## Static Friction Torque (αSTEP AS Series and ASC Series only)

For the electromagnetic brake specifications, this is the maximum holding torque at which the electromagnetic brake can hold the position.

# How to Read Speed – Torque Characteristics

The graph below is the characteristics that indicate the relationship between the speed and torque when a stepping motor is driven. The required speed and torque is always used when selecting a stepping motor. On the graph, the horizontal axis expresses the speed at motor output shaft while the vertical axis expresses the torque.

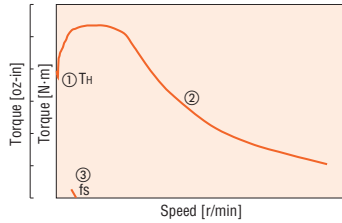

The speed – torque characteristics are determined by the motor and driver, so they vary greatly based upon the type of the driver used.

## ① Maximum Holding Torque

The holding torque (5-phase: 5-phase excitation, 2-phase: 2-phase excitation) is the maximum holding power (torque) the stepping motor has when power (rated current) is being supplied but the motor shaft is not rotating. At motor standstill, the driver's automatic current cutback function reduces the maximum holding torque by approximately 50% (approximately 40% for **UMK** and **CMK** Series).

## ② Pullout Torque

Pullout torque is the maximum torque that can be output at a given speed. When selecting a motor, be sure the required torque falls within this curve.

## ③ Maximum Starting Frequency (fs)

This is the maximum pulse speed at which the motor can start or stop instantaneously (without an acceleration or deceleration time) when the frictional load and inertial load of the stepping motor are 0. Driving the motor at greater than this pulse speed requires gradual acceleration or deceleration. This frequency drops when there is an inertial load on the motor. (Refer to Inertial load – starting frequency characteristics in technical reference → Page F-47)

The following figure shows the speed – torque characteristics of the 5-phase stepping motor and driver package **RK** Series.

