



Standard AC Motors

Introduction A-2	Introduction
Constant Speed MotorsA-9	Induction Motors World K Series/ BH Series A-19	Induction Motors
	Reversible Motors A-77 World K Series	Reversible Motors
	Electromagnetic Brake Motors A-109 World K Series/ BH Series	Electro-magnetic Brake Motors
	High-Strength, Long Life, Low-Noise V Series A-153	V Series
	Clutch and Brake Motors A-183	Clutch & Brake Motors
	Synchronous Motors A-193	Synchronous Motors
	Low-Speed Synchronous Motors A-203	Low-Speed Synchronous Motors
Watertight, Dust-Resistant Motors A-215	Watertight, Dust-Resistant Motors
Torque Motors A-225	Torque Motors
Right-Angle Gearheads A-239	Right-Angle Gearheads
Linear Heads A-259	Linear Heads
Brake Pack A-277	Brake Pack
Accessories A-287	Accessories
Installation A-305	Installation

Overview of Standard AC Motors

Standard AC motors are used generally as a power source for automated equipment, because these motors can be operated easily by connecting the motors directly to an AC power supply.

Oriental Motor offers standard AC motors incorporating various operating functions. A standard AC motor supports various applications by using with a brake pack or speed control circuit product, and combining with other mechanical components such as a gearhead or linear head.

Features

Easy Operation

Standard AC motors include single-phase motors used with a single-phase power supply and three-phase motors used with a three-phase power supply.

A single-phase motor can be operated simply by connecting it to a single-phase power supply via the supplied capacitor.

A three-phase motor does not require a capacitor. All you need is to connect the motor directly to a three-phase power supply.

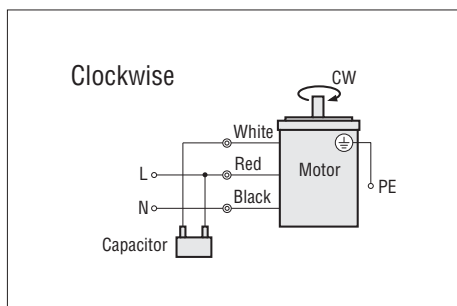

Induction Motors: Connection example for single-phase power supply input type

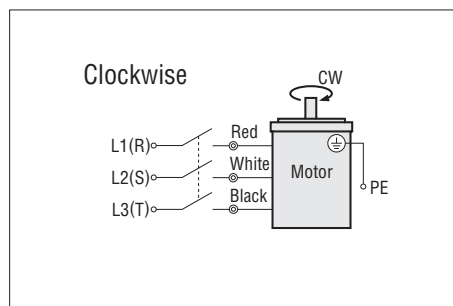

Induction Motors: Connection example for three-phase power supply input type

The Power Supply Frequency Determines the Speed

The basic speed (synchronous speed*) of a standard AC motor is determined by the power supply frequency and the number of poles. Many of our standard AC motors have four poles, so their synchronous speed is as follows:

50 Hz: 1500 r/min

60 Hz: 1800 r/min

The actual speed varies according to the load torque.

With our motors, the speed roughly falls within the following ranges at a load torque equivalent to the rated torque:

50 Hz: 1200 to 1300 r/min

60 Hz: 1450 to 1600 r/min

The rated speed of our standard AC motors are set within the above ranges and showed on each motor's specification page.

To calculate a more accurate machine speed, use the rated speed as a reference.

The power supply frequency varies from region to region. In the case of automated equipment used in different regions, change the gear ratio of the gearhead or take other appropriate measure to obtain the desired speed.

An Optimal Motor can be Selected According to the Load Torque

The torque generated by each standard AC motor is different depending on the motor frame size and length.

Oriental Motor offers standard AC motors with a frame size of 42 mm to 104 mm (1.65 in. to 4.09 in.) and output of 1 W to 200 W (1/750 HP to 1/4 HP). Select the optimal motor from the wide-ranging variations according to the load torque.

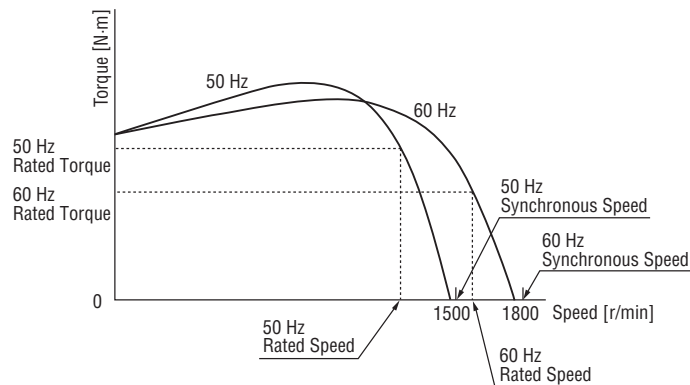

Speed - Torque Characteristics

*The synchronous speed is calculated by the formula below.

$$N_s = \frac{120 \times f}{P}$$

N_s : Synchronous Speed [r/min]

f : Power Supply Frequency [Hz]

P : Number of Poles (Many of our motors have four poles.)

● Motors Offering Various Operating Functions

We have induction motors and other motor types offering various operating functions to meet the diverse needs of customers.

Induction Motors

These motors can be operated easily from an AC power supply. Single-phase and three-phase motors are available.

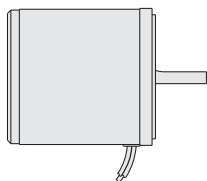

Reversible Motors

Generating a greater starting torque and having a built-in friction brake, these single-phase motors allow for instantaneous switching of rotation direction.

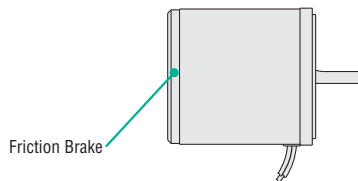

Electromagnetic Brake Motors

These motors adopt a power off activated type electromagnetic brake to hold the load in position when the power is cut off.

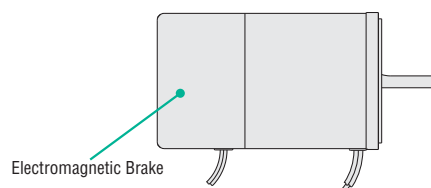

Clutch and Brake (C·B) Motors

Equipped with an electromagnetic clutch and brake at the motor output shaft. High frequency starting and stopping is possible while the motor is operating.

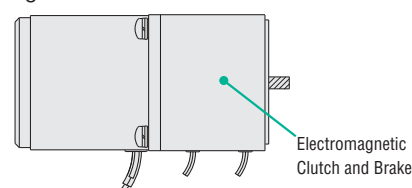

Synchronous Motors

A special rotor is used to provide rotation at a fixed speed in synchronization with the power supply frequency.

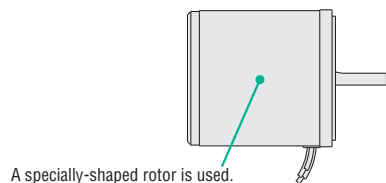

Low-Speed Synchronous Motors

Uses the same stator and rotor as stepping motors. The motor offers superb starting, stopping and reversing characteristics as well as synchronous operation.

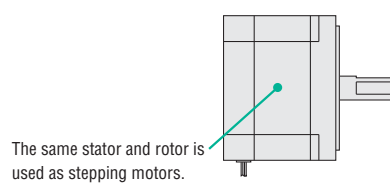

Watertight, Dust-Resistant Motors

Geared motors of excellent watertight, dust-resistant structure. These motors conform to the IEC Standard IP67.

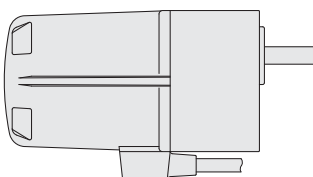

Torque Motors

A special rotor is used to provide large starting torque and sloping characteristics (torque is highest at zero speed and decreases steadily with increasing speed). The torque can be changed by changing the applied voltage.

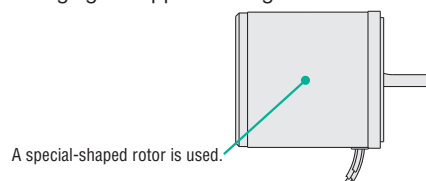

● Various Control Circuits are Available for Use with Standard AC Motors

Using a standard AC motor with a control circuit suppresses overrun and enables variable speed operation.

Note:

- Not all control circuits are compatible depending on the motor type, applicable voltage, etc.
- We also have many package models combining a control circuit with a motor.
- For details, check the pages where each product is listed.

Brake Pack

Upon receipt of a command from a programmable controller etc., a large braking current from the brake pack stops the motor instantaneously.

Applicable Products

- Single-Phase Induction Motors
- Reversible Motors
- Single-Phase Electromagnetic Brake Motors

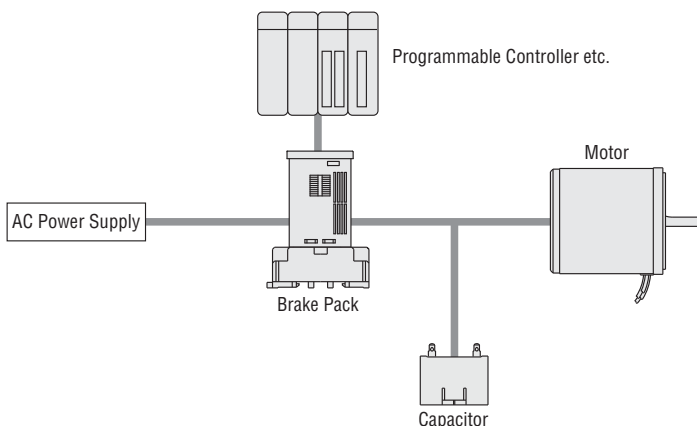

AC Motor Speed Control Systems

- When combined with a tachogenerator

A dedicated AC motor systems assembled with a tachogenerator is driven with a speed controller. Speed can be set with the speed controller's internal speed potentiometer or using an external speed potentiometer.

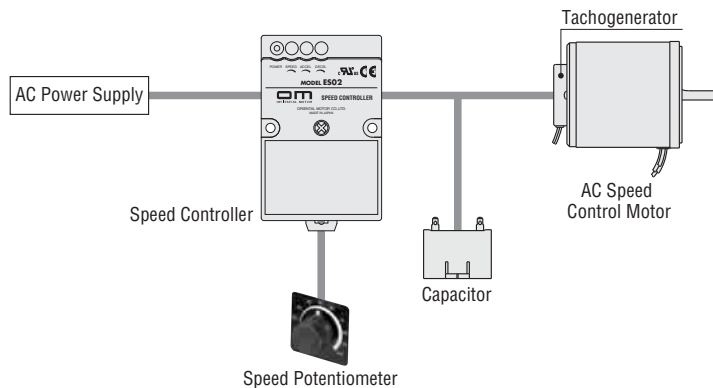

- When combined with a three-phase motor

Combined use of a speed controller with a three-phase induction motor enables motor operation at variable speed. Speed is set with the speed controller's internal speed potentiometer or using an external DC voltage.

Applicable Products

- Three-Phase Induction Motors
- Three-Phase Electromagnetic Brake Motors

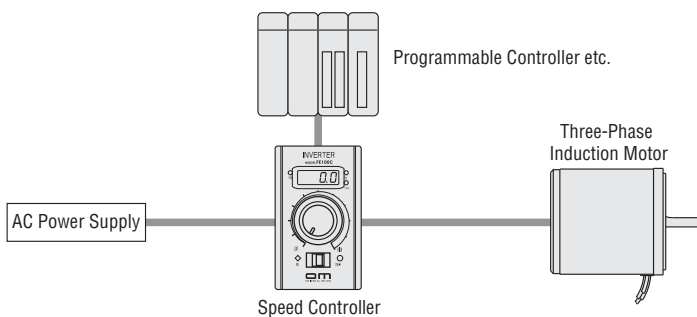

● Various Gearheads are Available for Assembly with Motors

We have various gearheads that convert the speed and torque of a standard AC motor to the speed or torque required by automated equipment, as well as linear heads that convert motor rotation to linear motion.

Since standard AC motors are designed with a standard flange mounting surface, the desired gearhead can be assembled according to your specific application.

Note:

- Available gearheads vary depending on the motor type.
- Not all gearheads are compatible. For details, check the pages where each product is listed.

Parallel Shaft Gearheads

The gear shaft is positioned in the same direction as (in parallel with) the motor shaft.

Decimal gearheads are also available.

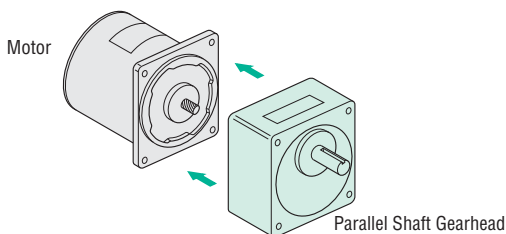

Right-Angle Gearheads

The gear shaft is positioned at right angles (90°) with the motor shaft.

Solid shaft and hollow shaft types are available.

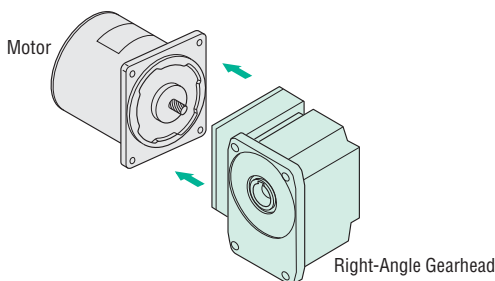

Linear Heads

The motor rotation is converted to linear motion using a rack-and-pinion mechanism.

Both horizontal and vertical types are available.

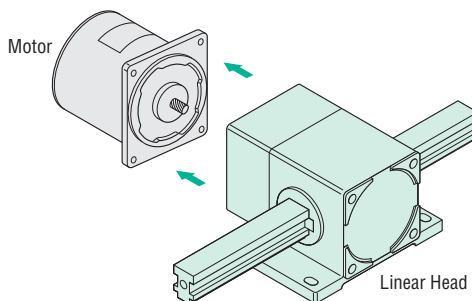

Types of Standard AC Motors

Constant Speed Motors

→ Page A-9

For Continuous Operation Induction Motors

→ Page A-19

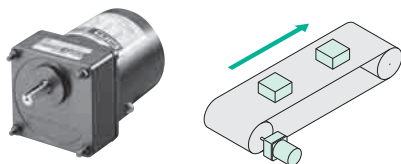

Suitable for applications where the motor is operated continuously in one direction.

For Bi-Directional Operation Reversible Motors

→ Page A-77

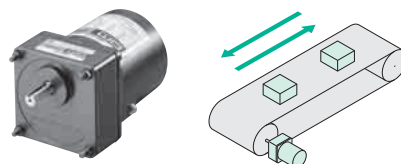

Suitable for applications where the motor reverses its direction repeatedly.

For Load Holding Electromagnetic Brake Motors

→ Page A-109

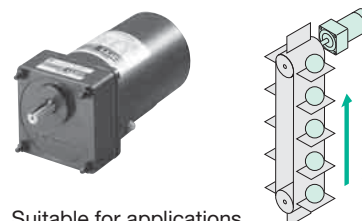

Suitable for applications where the load must always be held in place.

High-Strength, Long Life, Low Noise V Series

→ Page A-153



Induction Motors
Reversible Motors
Electromagnetic Brake Motors

Suitable for applications where noise reduction, high strength and long life is required.

For High-Frequency Start and Stop Operation Clutch and Brake Motors

→ Page A-183

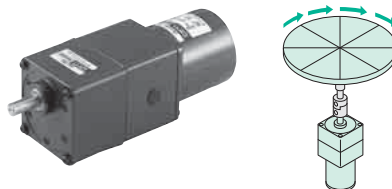

Ideal for high-frequency starting and stopping.

For Synchronous Rotation Synchronous Motors

→ Page A-193

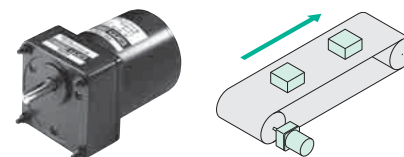

Suitable for applications where the motor is operated continuously in one direction at synchronous speed regardless of load torque.

For Synchronous Rotation Low-Speed Synchronous Motors

→ Page A-203

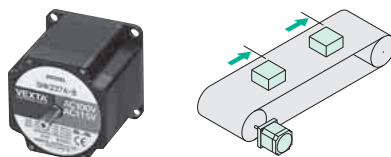

Suitable for applications where the motor is operated starting, stopping and reversing repeatedly and the motor is operated at synchronous speed regardless of load torque.

Watertight, Dust-Resistant Motors

→ Page A-215

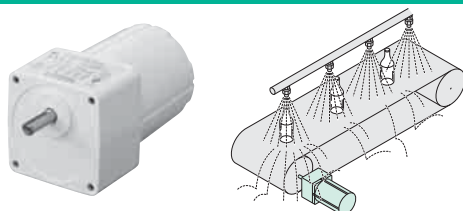

Suitable for applications where the equipment comes in contact with water or needs to be washed with water.

Torque Motors

→ Page A-225

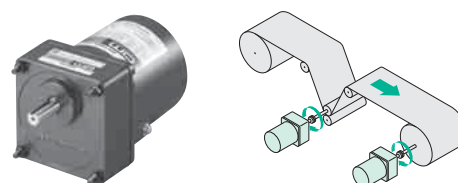

Suitable for winding and other operations involving tension control, as well as pushing operations.

Gearheads

Parallel Shaft Gearheads

→ Refer to the page of each motor.

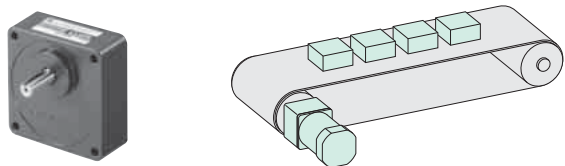

Installing a parallel shaft gearhead on a pinion shaft type motor allows the motor to reduce the speed and generate greater torque.

Right-Angle Gearheads

→ Page A-239

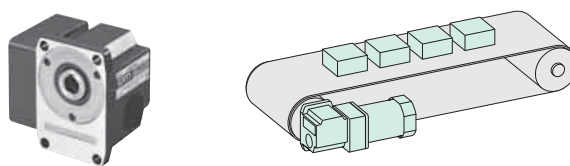

Suitable for applications where space saving is required.

Linear Motion Linear Heads

→ Page A-259

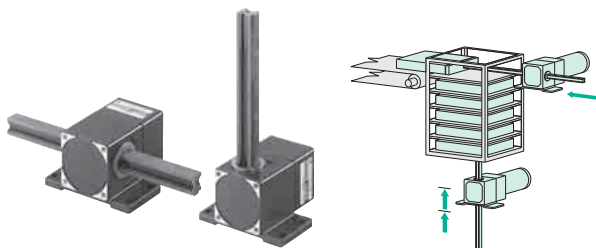

Linear motion can be achieved easily by installing a linear head on a pinion shaft type motor.

Instantaneous Stop Brake Pack

→ Page A-277

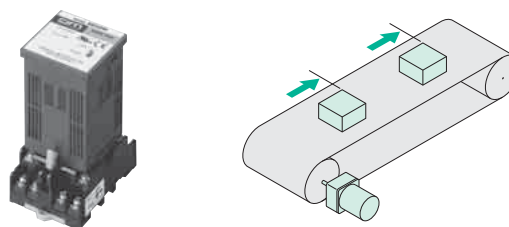

Suitable for applications where the overrun of an induction motor, reversible motor or electromagnetic brake motor should be suppressed.

Speed Control Systems

→ Page B-1

Brushless Motor Systems

→ Page B-15

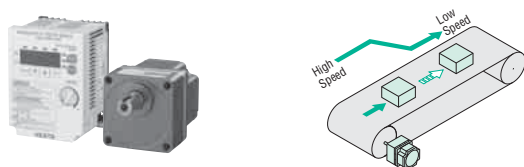

Suitable for applications where a wide speed control range is required.

AC Motor Systems

→ Page B-137

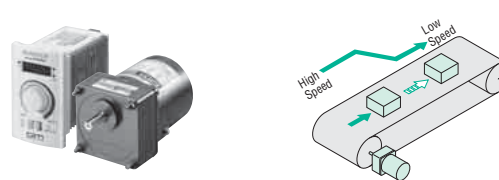

Suitable for applications where the motor speed needs to be varied.

Accessories

→ Page A-287



Various accessories are available that can be combined effectively with motors and gearheads. Selection is easy once you know which motor product you will be using.

Standard AC Motors

Constant Speed Motors









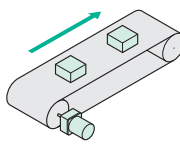

	Introduction
Induction Motors	Induction Motors
Reversible Motors	Reversible Motors
Electromagnetic Brake Motors	Electromagnetic Brake Motors
High-Strength, Long Life, Low Noise V Series	V Series
Clutch and Brake Motors	Clutch & Brake Motors
Synchronous Motors	Synchronous Motors
Low-Speed Synchronous Motors	Low-Speed Synchronous Motors

	Watertight, Dust-Resistant Motors
	Torque Motors
	Right-Angle Gearheads
	Linear Heads
	Brake Pack
	Accessories
	Installation

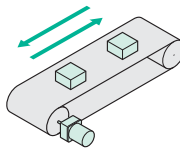
	Page
Features and Types of Constant Speed Motors.....	A-10
How to Read Specifications.....	A-12
Common Specifications.....	A-16
Induction Motors.....	A-19
Reversible Motors.....	A-77
Electromagnetic Brake Motors.....	A-109
V Series.....	A-153
Clutch and Brake Motors.....	A-183
Synchronous Motors.....	A-193
Low-Speed Synchronous Motors.....	A-203

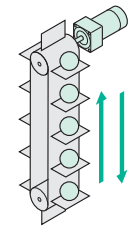
Features and Types of Constant Speed Motors

Constant speed motors come in various types as shown below. Select from a wide range of products depending on the application, required functions, output, etc.

Types	Features	Series	Frame Size mm (in.)/Output Power							
			□42 (□1.65)	□60 (□2.36)	□70 (□2.76)	□80 (□3.15)	□90 (□3.54)		□104 (□4.09)	
			1 W, 3 W (1/750 HP, 1/250 HP)	6 W (1/125 HP)	15 W (1/50 HP)	25 W (1/30 HP)	40 W (1/19 HP)	60 W (1/12 HP)	90 W (1/8 HP)	200 W (1/4 HP)
Induction Motors	<p>Suitable for applications where the motor is operated continuously in one direction.</p> 	<p>World K Series These motors conform to major safety standards and support global power supply voltages for use in major countries.</p>  <p>2-Pole, High-Speed Type</p>	●	●	●	●	●	●	●	
		<p>V Series Adopted High-Strength, Long Life, Low Noise gearheads. They also conform to major safety standards and support global power supply voltages.</p> 		●	●	●	●	●	●	
		<p>BH Series The BH Series provides high-output power of 200 W (1/4 HP) in a compact 104 mm (4.09 in.) square mounting configuration. They also conform to major safety standards and support global power supply voltages.</p> 								●
Reversible Motors	<p>Suitable for applications where the motor reverses its direction repeatedly.</p> 	<p>World K Series These motors conform to major safety standards and support global power supply voltages for use in major countries.</p> 	● 1 W (1/750 HP)	●	●	●	●	●	●	
		<p>V Series Adopted High-Strength, Long Life, Low Noise gearheads. They also conform to major safety standards and support global power supply voltages.</p> 		●	●	●	●	●	●	
Electromagnetic Brake Motors	<p>Suitable for applications where the load must always be held in place.</p> 	<p>World K Series These motors conform to major safety standards and support global power supply voltages for use in major countries.</p> 	●	●	●	●	●	●		
		<p>V Series Adopted High-Strength, Long Life, Low Noise gearheads. They also conform to major safety standards and support global power supply voltages.</p> 		●	●	●	●	●	●	
		<p>BH Series The BH Series provides high-output power of 200 W (1/4 HP) in a compact 104 mm (4.09 in.) square mounting configuration. They also conform to major safety standards and support global power supply voltages.</p> 								●

Page A-19

Page A-77

Page A-109

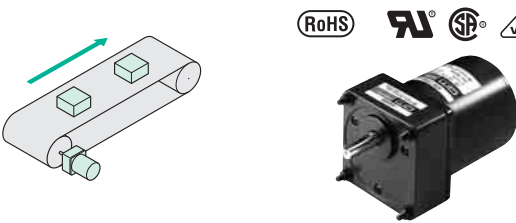
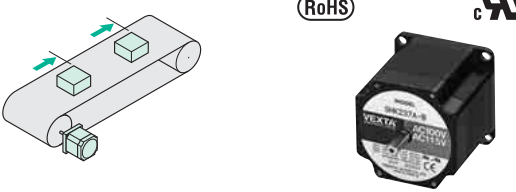
Types	Features	Frame Size mm (in.)/Output Power						
		□42 (□1.65)	□60 (□2.36)	□70 (□2.76)	□80 (□3.15)	□90 (□3.54)		
Clutch and Brake Motors	<p>This motor combines a power on activated type clutch and brake with an induction motor. It is ideal for high-frequency starting and stopping.</p> 		●		●	●	●	●
Synchronous Motors	<p>Suitable for applications where the motor is operated at synchronous speed continuously in one direction regardless of load torque.</p> 		●	●	●	●		
Low-Speed Synchronous Motors	<p>Suitable for applications where the motor is operated starting, stopping and reversing repeatedly and the motor is operated at synchronous speed regardless of load torque.</p> 	●*	●*				●*	

*For low-speed synchronous motors, only the frame size is represented.

● How to Select a Brake Motor

◇ Selecting Based on Stopping Accuracy

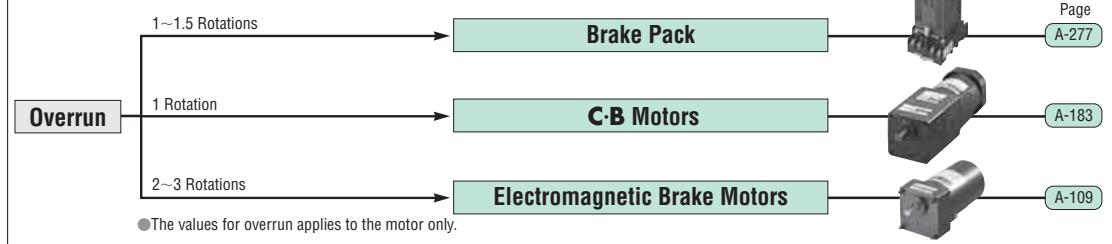

● For low-speed synchronous motors, the motor can be stopped instantly within $\pm 10^\circ$ of stopping accuracy by turning off the power supply. Refer to page A-203 for details.

◇ Selecting Based on Frequency of Use

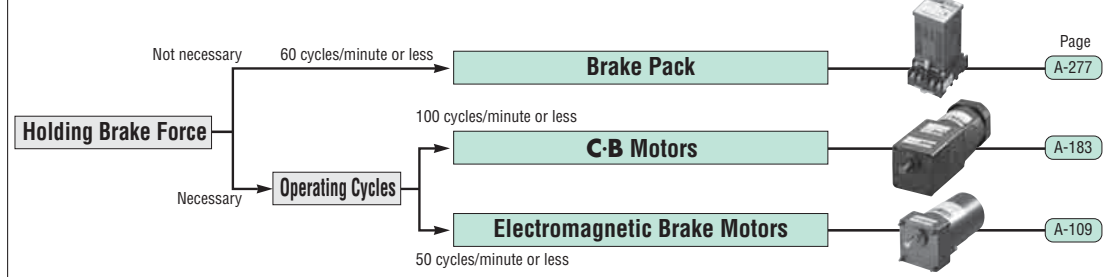

Notes:

- The operating cycles are based merely on brake response. The value specified above is the maximum, so it may not be possible to repeat braking operation at this frequency. In an actual application, be certain the surface temperature of the motor case remains at 90°C (194°F) or less.
- For low-speed synchronous motors, if operated within the permissible load inertia, the motor can start and reverse within 1.5 cycles of power supply frequency. Refer to page A-203 for details.

- Introduction
- Induction Motors
- Reversible Motors
- Electro-magnetic Brake Motors
- V Series
- Clutch & Brake Motors
- Synchronous Motors
- Low-Speed Synchronous Motors
- Water-tight, Dust-Resistant Motors
- Torque Motors
- Right-Angle Gearheads
- Linear Heads
- Brake Pack
- Accessories
- Installation

How to Read Specifications

When selecting a motor and gearhead, you should read the specifications to make sure that the motor you select meets your application needs. Shown below is an explanation of how you should read the specifications on some important items.

How to Read Motor Specifications

Motor Specifications

Motor Specifications Table (Example)

Specifications – Continuous Rating ⑥

Model Upper Model Name: Pinion Shaft Type Lower Model Name (): Round Shaft Type		① Output Power	Voltage	Frequency	② Current	③ Starting Torque	④ Rated Torque	⑤ Rated Speed	Capacitor
Lead Wire Type Dimension ①	Terminal Box Type Dimension ②	W HP	VAC	Hz	A	mN·m oz·in	mN·m oz·in	r/min	μF
ⓉP 4IK25GN-AW2U (4IK25A-AW2U)	4IK25GN-AW2TU (4IK25A-AW2TU)	25	Single-Phase 110	60	0.46	120	170	1450	6.5
		1/30	Single-Phase 115						

① Output Power: The amount of work that can be performed in a given period of time. It can be used as a criteria for motor capability.

② Current: The current value used by a motor when the motor is producing rated torque.

③ Starting Torque: This term refers to the torque generated the instant the motor starts. If the motor is subjected to a friction load smaller than this torque, it will operate.

④ Rated Torque: This is the torque created when the motor is operating most efficiently. Though the maximum torque is far greater, rated torque should, from the standpoint of utility, be the highest torque.

⑤ Rated Speed: This is the speed of the motor when the motor is producing rated torque.

⑥ Rating: The time that a motor can operate continuously at rated output (torque). With a continuous rating, a motor can operate continuously.

Electromagnetic Brake (Power Off Activated Type)

Specifications Table (Example)

Motor Model	Voltage VAC	Frequency Hz	Current A	Input W	① Holding Brake Torque mN·m oz·in
4RK25GN-AW2MU	Single-Phase 110	60	0.09	6	100
4RK25A-AW2MU	Single-Phase 115				14.2

① Holding Brake Torque: This refers to the holding brake torque of the electromagnetic brake and expresses the size of holding torque at the motor output shaft.

When a gearhead is connected, calculate the holding torque at the gearhead output shaft with the following formula.

Holding torque at the gearhead output shaft $T_G = T_M \times i$ T_G : Holding torque at the gearhead output shaft
 T_M : Holding torque at the motor output shaft
 i : Gearhead gear ratio

● Permissible Overhung Load and Permissible Thrust Load of Motors

Specifications Table for Permissible Overhung Load (Example) ①

Motor			Permissible Overhung Load			
Frame Size	Output Shaft Diameter	Series	10 mm (0.39 in.) from shaft end		20 mm (0.79 in.) from shaft end	
□ mm (in.)	φ mm (in.)		N	lb.	N	lb.
60 (2.36)	6 (0.2362)	World K	50	11.2	110	24

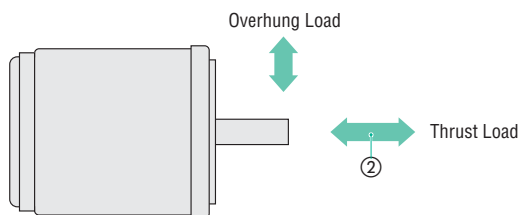

- ① Permissible Overhung Load: The value ① shown in the table above is the one for the permissible overhung load. As shown in the figure to the left, this term refers to the permissible value of the load applied in a direction perpendicular to the motor shaft.
- ② Permissible Thrust Load: As shown in the figure to the left, this term refers to the permissible value of the load applied in the axial direction to the motor shaft. Keep the thrust load to half or less of motor mass.

The calculating method of overhung load applied on the output shaft is the same as for a gear shaft. Refer to the permissible overhung load and permissible thrust load of gearheads for details. Permissible overhung load and permissible thrust load of gearheads → Page A-15

■ How to Read Gearhead Specifications

Some gearheads other than those for constant speed motors are listed.

● Gearmotor – Torque Table

Gearmotor – Torque Table (Example)

◇ 60 Hz

Unit = Upper values: N·m/ Lower values: lb-in

Model Motor/ Gearhead	Speed r/min	600	500	360	300	240	200	144	120	100	72	60	50	36	30	24	20	18	15	12	10
	Gear Ratio	3	3.6	5	6	7.5	9	12.5	15	18	25	30	36	50	60	75	90	100	120	150	180
4IK25GN-AW2 □U 4IK25GN-CW2 □E	4GN □SA	0.41 3.6	0.50 4.4	0.69 6.1	0.83 7.3	1.0 8.8	1.2 10.6	1.7 15.0	2.1 18.5	2.5 22	3.1 27	3.7 32	4.5 39	5.6 49	6.7 59	8 70	8 70	8 70	8 70	8 70	8 70

① Permissible Torque: It refers to the value of load torque driven by the gearhead's output shaft. Each value is shown for the corresponding gear ratio.

Permissible torque when a gearhead is connected can be calculated with the formula below.

Permissible torque for some products are omitted. In that case, use the formula below to calculate the permissible torque.

Permissible torque $T_G = T_M \times i \times \eta$ T_G : Permissible torque of gearhead
 T_M : Motor torque
 i : Gearhead gear ratio
 η : Gearhead efficiency

● Gearhead Efficiency

Model	Gear Ratio	3	3.6	5	6	7.5	9	12.5	15	18	25	30	36	50	60	75	90	100	120	150	180	250	300	360
2GN □SA, 3GN □SA, 4GN □SA 5GN □SA, 5GC □KA		81%										73%			66%									
0GN □KA, 5GE □SA, 5GU □KA, 5GCH □KA		81%						73%			66%			59%										
BH6G2 -□		90%						86%			81%													
GV2G □, GV3G □, GV4G □		90%						86%			81%													
GVH5G □		90%						86%			81%													
GVR5G □		90%						86%			81%													

● For **BH6G2**-□RH and **BH6G2**-□RA, gearhead efficiency of all gear ratio is 73% at the rated speed and starting.

● Gearhead efficiency of all the decimal gearheads is 81%.

● For the efficiency of right-angle gearheads, refer to the page for right-angle gearheads. The gearhead efficiency of right-angle gearheads → Page A-242

Model	Gear Ratio	5	10	15	20	30	50	100	200
GFS2G □		90%				86%		81%	
GFS4G □		90%				86%		81%	
GFS5G □, GFB5G □		90%				86%		81%	
GFS6G □		90%				86%		81%	

Model	Gear Ratio	5	10	15	20	30	50	100	200
GFS2G □FR		80%		85%					
GFS4G □FR		85%							
GFS5G □FR		85%							

● **Maximum Permissible Torque**

The gearhead output torque increases proportionally as the gear ratio increases. However, the load torque is saturated at a certain gear ratio because of the gear materials and other conditions. This torque is called the maximum permissible torque. The maximum permissible torque of typical gearheads are shown in the figure to the right.

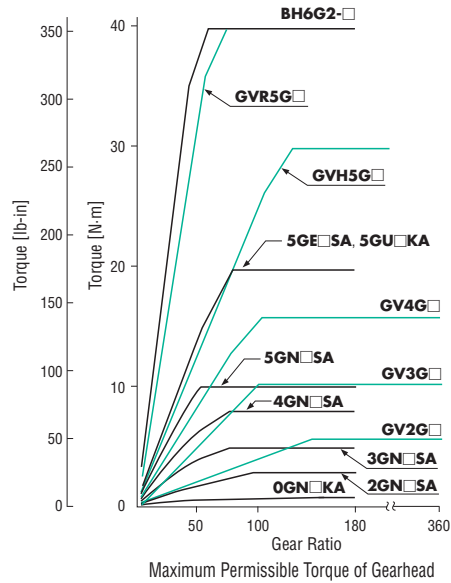

● **Speed and Rotation Direction**

Gearmotor – Torque Table (Example)

◇ 60 Hz

Unit = Upper values: N-m/ Lower values: lb-in

Model Motor/ Gearhead	Speed r/min	600	500	360	300	240	200	144	120	100	72	60	50	36	30	24	20	18	15	12	10
	Gear Ratio	3	3.6	5	6	7.5	9	12.5	15	18	25	30	36	50	60	75	90	100	120	150	180
4IK25GN-AW2 □ □ U 4IK25GN-CW2 □ □ E	4GN □ SA	0.41 3.6	0.50 4.4	0.69 6.1	0.83 7.3	1.0 8.8	1.2 10.6	1.7 15.0	2.1 18.5	2.5 22	3.1 27	3.7 32	4.5 39	5.6 49	6.7 59	8 70	8 70	8 70	8 70	8 70	8 70

① Speed: This refers to the speed at the gearhead output shaft. The speeds, depending on gear ratio, are shown in the "Gearmotor – Torque Table." The speed is calculated by dividing the motor's synchronous speed by the gear ratio. The actual speed is 2~20% less than the displayed value depending on the load.

The speed is calculated with the following formula.

$$\text{Speed } N_G = \frac{N_M}{i}$$

N_G : Gearhead speed [r/min]
 N_M : Motor speed [r/min]
 i : Gearhead gear ratio

② Rotation Direction: This refers to the rotation direction viewed from the output shaft. A colored background (□) indicates gear shaft rotation in the same direction as the motor shaft, while the others rotate in the opposite direction. The direction of gearhead shaft rotation may differ from motor shaft rotation depending on the gear ratio of the gearhead. The gear ratio and rotation direction of each gearhead is shown in the table below.

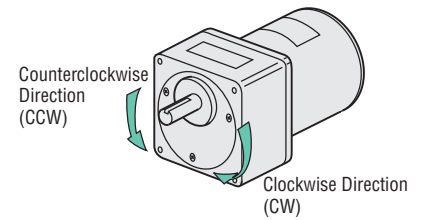

◇ **Gear Ratio and Rotation Direction of Gearhead**

□ Same direction as the motor shaft
 □ Opposite direction as the motor shaft

Model	Gear Ratio	3	3.6	5	6	7.5	9	12.5	15	18	25	30	36	50	60	75	90	100	120	150	180	250	300	360
2GN □ SA, 3GN □ SA, 4GN □ SA, 5GN □ SA, 5GC □ KA		□	□	□	□	□	□	□	□	□	□	□	□	□	□	□	□	□	□	□	□	□	□	□
OGN □ KA, 5GE □ SA, 5GU □ KA, 5GCH □ KA		□	□	□	□	□	□	□	□	□	□	□	□	□	□	□	□	□	□	□	□	□	□	□
BH6G2 □		□	□	□	□	□	□	□	□	□	□	□	□	□	□	□	□	□	□	□	□	□	□	□
GV2G □, GV3G □, GV4G □		□	□	□	□	□	□	□	□	□	□	□	□	□	□	□	□	□	□	□	□	□	□	□
GVH5G □		□	□	□	□	□	□	□	□	□	□	□	□	□	□	□	□	□	□	□	□	□	□	□
GVR5G □		□	□	□	□	□	□	□	□	□	□	□	□	□	□	□	□	□	□	□	□	□	□	□

Connection of a decimal gearhead reduces the speed by 10:1, but does not affect the rotation direction.

Model	Gear Ratio	5	10	15	20	30	50	100	200
GFS2G □		□	□	□	□	□	□	□	□
GFS4G □		□	□	□	□	□	□	□	□
GFS5G □, GFB5G □		□	□	□	□	□	□	□	□
GFS6G □		□	□	□	□	□	□	□	□

● Permissible Overhung Load and Permissible Thrust Load of Gearheads

Specifications Table for Permissible Overhung Load and Permissible Thrust Load (Example)

Model	Gear Ratio	Max. Permissible Torque		Permissible Overhung Load				Permissible Thrust Load	
				10 mm (0.39 in.) from shaft end		20 mm (0.79 in.) from shaft end			
		N·m	lb-in	N	lb.	N	lb.	N	lb.
4GN□SA	3~18	8.0	70	100	22	150	33	50	11.2
	25~180			200	45	300	67		

- ① Permissible Overhung Load: The value ① shown in the table above is the one for the permissible overhung load. This term refers to the permissible value of the load applied in a direction perpendicular to the gearhead output shaft as shown in the figure to the right.
- ② Permissible Thrust Load: The value ② shown in the table above is the one for permissible thrust load. This term refers to the permissible value of the load applied in the axial direction to the gearhead output shaft as shown in the figure to the right.

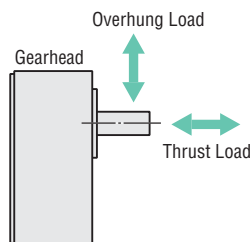

When a chain, gear, belt, etc. is used as the transmission mechanism, the overhung load is always applied on the gearhead output shaft. The overhung load is calculated with the following formula.

$$\text{Overhung load } W = \frac{K \times T \times f}{\gamma}$$

- W : Overhung load [N]
- K : Load coefficient for driving method (on the right)
- T : Torque at gearhead output shaft [N·m]
- f : Service factor (on the right)
- γ : Effective radius of gear or pulleys [m]

◇ Load Coefficient for Driving Method (K)

Drive System	K
Chain or synchronous belt	1
Gear	1.25
V-belt	1.5
Flat belt	2.5

◇ Service Factor (f)

Load Type	Example	Factor f
Uniform Load	· Uni-directional continuous operation · For driving belt conveyors and film rollers that are subject to minimal load fluctuation	1.0
Light Impact	· Frequent starting and stopping · Cam drive and inertial body positioning	1.5
Medium Impact	· Frequent instantaneous bi-directional operation, starting and stopping of reversible motors · Frequent instantaneous stopping by brake pack of AC motors · Frequent instantaneous starting and stopping by brushless motors	2.0

● Permissible Load Inertia J of Gearhead

This refers to the permissible value for load inertia (J) at the gearhead output shaft. Convert the permissible value at the motor output shaft into the permissible value at the gearhead output shaft with the following formula.

- Gear ratio 3:1~50:1 $J_G = J_M \times i^2$
- Gear ratio 60:1 or higher $J_G = J_M \times 2500$
- J_G : Permissible load inertia at the gearhead output shaft J ($\times 10^{-4} \text{ kg}\cdot\text{m}^2$)
- J_M : Permissible load inertia at the motor shaft J ($\times 10^{-4} \text{ kg}\cdot\text{m}^2$)
- i : Gear ratio (Example: $i = 3$ means the gear ratio of 3:1)

● Permissible Load Inertia at the Motor Shaft (Example)

Number of Phase	Frame Size	Output Power	Permissible Load Inertia at the Motor Shaft J [$\times 10^{-4} \text{ kg}\cdot\text{m}^2$ (oz-in 2)]
Single-Phase	□80 mm (□3.15 in.)	25 W (1/30 HP)	0.31 (1.70)

For some products that are combination types, the permissible load inertia at the gearhead output shaft is shown as the specifications values, divided with each gear ratio.

Common Specifications

Some specifications other than the constant speed motors are listed.

■ Permissible Overhung Load and Permissible Thrust Load of Motors

● Permissible Overhung Load

Motor			Permissible Overhung Load			
Frame Size □ mm (in.)	Output Shaft Diameter φ mm (in.)	Series	10 mm (0.39 in.) from shaft end		20 mm (0.79 in.) from shaft end	
			N	lb.	N	lb.
42 (1.65)	5 (0.1969)	World K	40	9.0	—	—
60 (2.36)	6 (0.2362)	World K	50	11.2	110	24
70 (2.76)	6 (0.2362)	World K	40	9.0	60	13.5
80 (3.15)	8 (0.3150)	World K	90	20	140	31
	10 (0.3937)	World K	110	24	120	27
90 (3.54)	10 (0.3937)	World K	140	31	200	45
	12 (0.4724)	World K	240	54	270	60
104 (4.09)	14 (0.5512)	BH, BHF	320	72	350	78

● Permissible Thrust Load

Avoid thrust load as much as possible. If thrust load is unavoidable, keep it to half or less of the motor mass.

■ Permissible Overhung Load and Permissible Thrust Load of Gearheads

Model	Gear Ratio	Max. Permissible Torque		Permissible Overhung Load				Permissible Thrust Load	
		N-m	lb-in	10 mm (0.39 in.) from shaft end		20 mm (0.79 in.) from shaft end		N	lb.
				N	lb.	N	lb.		
0GN □ KA	3~180	1.0	8.8	20	4.5	—	—	15	3.3
2GN □ SA	3~18	3.0	26	50	11.2	80	18	30	6.7
	25~180			120	27	180	40		
3GN □ SA	3~18	5.0	44	80	18	120	27	40	9
	25~180			150	33	250	56		
4GN □ SA	3~18	8.0	70	100	22	150	33	50	11.2
	25~180			200	45	300	67		
5GN □ SA 5GC □ KA	3~18	10	88	250	56	350	78	100	22
	25~180			300	67	450	101		
5GE □ SA 5GU □ KA 5GCH □ KA	3~9	20	177	400	90	500	112	150	33
	12.5~18			450	101	600	135		
	25~180			500	112	700	157		
GV2G □	5~9	6.0	53	100	22	150	33	40	9
	12.5~25			150	33	200	45		
	30~360			200	45	300	67		
GV3G □	5~9	10	88	150	33	200	45	80	18
	12.5~25			200	45	300	67		
	30~360			300	67	400	90		
GV4G □	5~9	16	141	200	45	250	56	100	22
	12.5~25			300	67	350	78		
	30~360			450	101	550	123		
GVH5G □	5~9	30	260	400	90	500	112	150	33
	12.5~18			450	101	600	135		
	25~300			500	112	700	157		
GVR5G □	5~9	40	350	400	90	500	112	150	33
	12.5~18			450	101	600	135		
	25~180			500	112	700	157		
BH6G2 -□	3~36	40	350	550	123	800	180	200	45
	50~180			650	146	1000	220		
BH6G2 -□ RH	5~36	60	530	1200*	270	1100*	240	300	67
	50~180			2200*	490	2000*	450		
BH6G2 -□ RA	5~36	60	530	900	200	1000	220	300	67
	50~180			1700	380	1850	410		

Model	Gear Ratio	Max. Permissible Torque		Permissible Overhung Load				Permissible Thrust Load	
				10 mm (0.39 in.) from shaft end		20 mm (0.79 in.) from shaft end			
		N·m	lb·in	N	lb.	N	lb.	N	lb.
FPW425□	3~18	8.0	70	100	22	150	33	50	11.2
	25~180			200	45	300	67		
FPW540□	3~18	10	88	250	56	350	78	100	22
	25~180			300	67	450	101		
FPW560□	3~9	15	132	400	90	500	112	150	33
	12.5~18			450	101	600	135		
	25~180			500	112	700	157		
FPW690□	3~9	30	260	550	123	800	180	200	45
	12.5~180			650	146	1000	220		

● For permissible overhung load and permissible thrust load of right-angle gearheads, refer to the page where the products are listed. → Page A-241

* For **BH6G2-□RH** (Gearhead for **BH** Series and **BHF** Series right-angle, hollow shaft combination type), the permissible overhung load is the value at the distance from the flange mounting surface.

The permissible overhung load at each distance is calculated with the formula below.

◇ Calculating the Permissible Overhung Load for **BH6G2-□RH**

When the end of the shaft being driven is not supported by a bearing as shown in the figure below calculate the permissible overhung load using the following formula. (This mechanism is the most demanding state in terms of overhung load.)

- Gear ratio 5:1~36:1

$$\text{Permissible overhung load } W [\text{N}] = \frac{87.5}{87.5 + L_P} \times 1350 [\text{N}]$$

1350 [N] : Permissible overhung load at the flange mounting surface

- Gear ratio 50:1~180:1

$$\text{Permissible overhung load } W [\text{N}] = \frac{87.5}{87.5 + L_P} \times 2450 [\text{N}]$$

2450 [N] : Permissible overhung load at the flange mounting surface

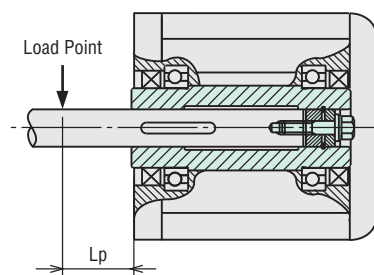

■ Permissible Load Inertia J of Gearhead

When a high load inertia (J) is connected to a gearhead, high torque is exerted instantaneously on the gearhead when starting in frequent, intermittent operations (or when stopped by an electromagnetic brake, or when stopped instantaneously by a brake pack).

The table below gives values for permissible load inertia at the motor shaft. Use the motor and gearhead within these parameters. The permissible load inertia for three-phase motors is the value when reversing after a stop.

The permissible load inertia (J) at the gearhead output shaft is calculated with the following formula.

The life of the gearhead when operating at the permissible load inertia with instantaneous stop of motors with electromagnetic brakes, brake pack or speed control motors is approximately two million cycles.

● Permissible Load Inertia at the Gearhead Output Shaft

$$\begin{aligned} \text{Gear ratio 3:1~50:1} & \quad J_G = J_M \times i^2 & \quad J_G & : \text{Permissible load inertia at the gearhead output shaft } J (\times 10^{-4} \text{ kg}\cdot\text{m}^2) \\ \text{Gear ratio 60:1 or higher} & \quad J_G = J_M \times 2500 & \quad J_M & : \text{Permissible load inertia at the motor shaft } J (\times 10^{-4} \text{ kg}\cdot\text{m}^2) \\ & & \quad i & : \text{Gear ratio (Example: } i = 3 \text{ means the gear ratio of 3:1)} \end{aligned}$$

● Permissible Load Inertia at the Motor Shaft

Number of Phase	Frame Size	Output Power	Permissible Load Inertia at the Motor Shaft J [$\times 10^{-4}$ kg·m ² (oz·in ²)]
Single-Phase	□42 mm (□1.65 in.)	1 W, 3 W (1/750 HP, 1/250 HP)	0.016 (0.088)
	□60 mm (□2.36 in.)	6 W (1/125 HP)	0.062 (0.34)
	□70 mm (□2.76 in.)	15 W (1/50 HP)	0.14 (0.77)
	□80 mm (□3.15 in.)	25 W (1/30 HP)	0.31 (1.70)
	□90 mm (□3.54 in.)	40 W (1/19 HP)	0.75 (4.1) [1.1 (6.0)]*
		60 W (1/12 HP)	1.1 (6.0)
		90 W (1/8 HP)	1.1 (6.0)
□104 mm (□4.09 in.)	200 W (1/4 HP)	2.0 (10.9)	
Three-Phase	□60 mm (□2.36 in.)	6 W (1/125 HP)	0.062 (0.34)
	□80 mm (□3.15 in.)	25 W (1/30 HP)	0.31 (1.70)
	□90 mm (□3.54 in.)	40 W (1/19 HP)	0.75 (4.1) [1.1 (6.0)]*
		60 W (1/12 HP)	1.1 (6.0)
		90 W (1/8 HP)	1.1 (6.0)
	□104 mm (□4.09 in.)	200 W (1/4 HP)	2.0 (10.9)

* Values in the brackets are for the **V** Series.

