

80/20[®] Inc.

The Industrial Erector Set

NEW **PRODUCT
SUPPLEMENT**

**ADDITIONS TO PROFILES, FASTENERS,
ACCESSORIES, LINEAR BEARINGS & MORE**

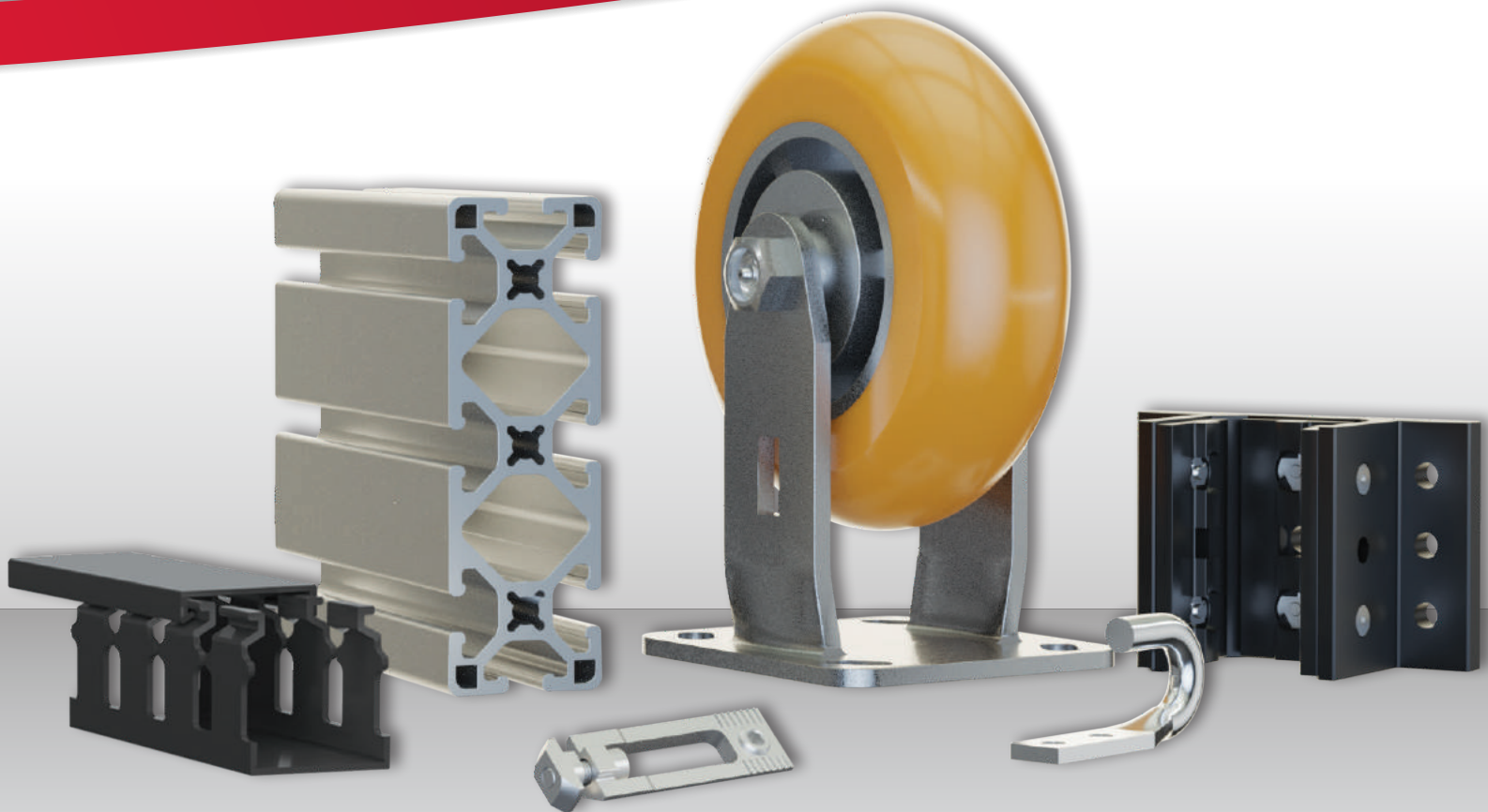

**NEW**

Products 2018

80/20® Inc.*The Industrial Erector Set®*

Quick Reference Guide

Profiles

1545-LS	2
---------------	---

Fasteners

Milling Connector	3
Hidden Corner Connector	4
Central Connector	5
2 Way - Light Squared Corner Connector	6
3 Way - Light Squared Corner Connector	7

Floor To Frame

High-Capacity Swivel Caster	8
High-Capacity Rigid Caster	9

Finish Your Frame

Economy T-Slot Cover	10
Wire Housing	11
Wire Housing Cover	12
Vertical Mount Hook	13
Horizontal Mount Hook	14
Heavy Duty Monitor Mount	15

Finish Your Frame (Continued)

Magnetic Tool Holder	16
3M™ VHB™ Tape	17

Add-On Components

3 Slot Mount - Dbl Flange Short Linear Bearing	18
3 Slot Mount - Dbl Flange Long Linear Bearing	19
Single-Keyed Standard Linear Bearing Pad	20
Linear Bearing Shim Stock	21
“L” Handle Linear Bearing Brake Kit	22

Structural Shapes

Double Flange Bearing Profile	23
-------------------------------------	----

Tools

Six Lobe Tools	24
----------------------	----

Machining Services

Central Connector Profile Milling	25
Central Connector Clearance Notch	26
Hidden Corner Connector Clearance Notch	27

Important Ordering Information

Visit www.8020.net for the most up to date information on product specifications, shipping and lead times, warranties, and pricing. This New Product Supplement supersedes all previous pricing published by 80/20® Inc. All prices are U.S. dollars.

3M™ and VHB™ are registered trademarks of 3M Company.

NEW

Products 2018

80/20® Inc.The **Industrial Erector Set®**

1545-LS Profile: 1.50" X 4.50" Lite Smooth Surface T-Slotted Profile - Eight Open T-Slots

1545-LS is a 1.50" x 4.50" fractional 15 series rectangular T-slot profile with eight open T-slots, one on each 1.50" face and three on each 4.50" face. The 1545-LS profile is the light-duty version in the 1545 profile family. It is smooth, which makes it resistant to dirt and debris buildup while also being easy to clean. The 1545-LS profile is compatible with all 15 series fasteners, and lends itself to clean room applications, guards, enclosures, or workstations. The eight open T-slots enable access from any direction and are useful for mounting accessories.

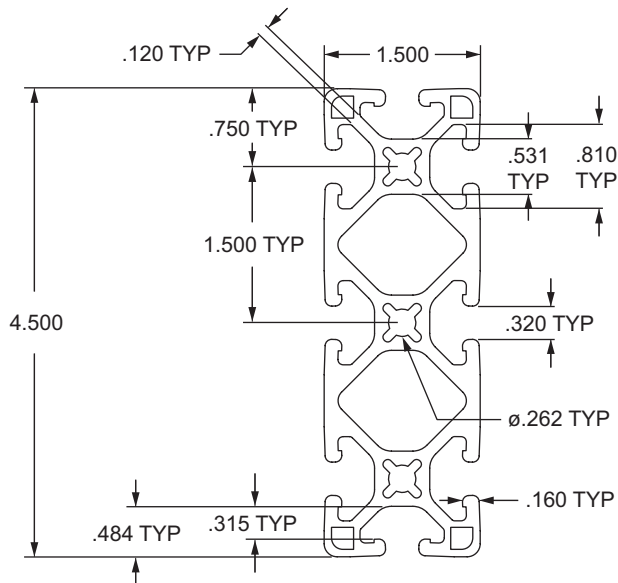

Part No.	Series	Stock Length	Material	Alloy*	Finish	Drop Lock	Moment of Inertia	Surface Area	Yield Strength	Modulus of Elasticity	Weight	Price
1545-LS	15	per inch	Aluminum	6105-T5	Clear Anodize	2°	IX = 4.4732 cm ⁴ IY = 0.6251 cm ⁴	2.492 in. ²	35,000 psi	10,200,000 lb / in. ²	0.242 lb / in. ²	\$1.170 / in
1545-LS-145		145"										\$170.17 ea.
1545-LS-242		242"										\$284.02 ea.
1545-LS-Black-FB		per inch			Black Anodize							\$1.500 / in
1545-LS-145-Black-FB		145"										\$217.50 ea.
1545-LS-242-Black-FB		242"										\$363.00 ea.

* Or comparable

Standard Machining Services

Service No.	Series	Service Description	Catalog 22 Page
7021	15	Cut to Length	851
7050	15	Access Hole	855
7040	15	Anchor Counterbore	857
7026	15	Tap Profile End	853

NEW

Products 2018

80/20® Inc.

The **Industrial Erector Set**®

Milling Connector

The milling connector provides a strong, internal fastening method that requires no profile machining. It allows infinite positioning along the mating profile and can be used even when the mating profile end is captivated. The point of the set screw bites into the bottom of the T-slot profile, making it a secure connection. The milling connector can be used in pairs.

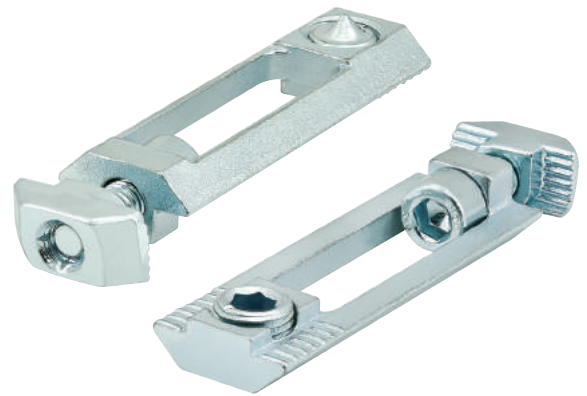
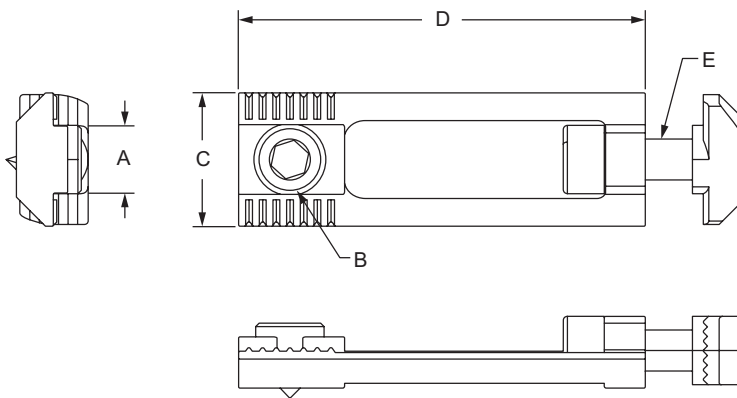

Part No.	Series	Material	Color	A	B	C	D	E	Weight	Price
14116	30	Steel	Bright	7.80mm	M8 x 11	16.00mm	57.50mm	M5 x 14	.0499 kg	\$5.25 ea.
14132	15 40			7.80mm	M8 x 11	18.00mm	57.50mm	M5 x 16	.0544 kg	\$5.35 ea.
14133	45			9.80mm	M10 x 11	19.50mm	59.50mm	M6 x 20	.0680 kg	\$5.55 ea.

Milling Connector Assembly

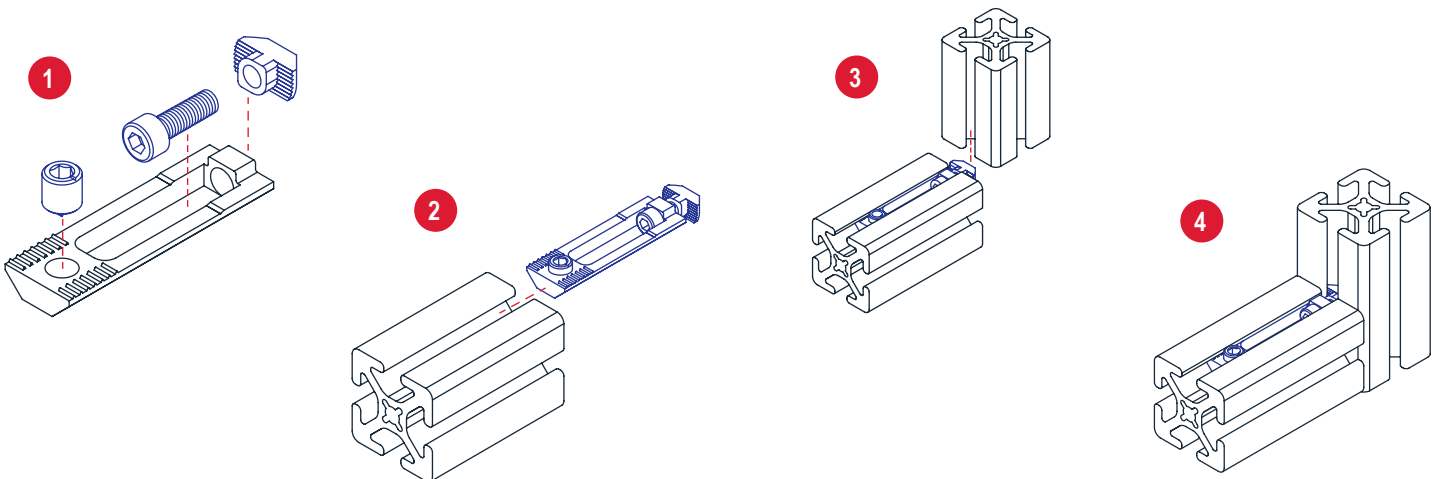

NEW

Products 2018

80/20® Inc.

The **Industrial Erector Set**®

Hidden Corner Connector

The hidden corner connector provides a 90 degree hidden corner connection. The corner connector comes with set screws that allow for quick, easy connections. This connection can be between the inside of two profiles or between the inside of one profile and the outside of the second profile. The hidden corner connector is die cast and does not require any machining, making it a cost-effective fastening option.

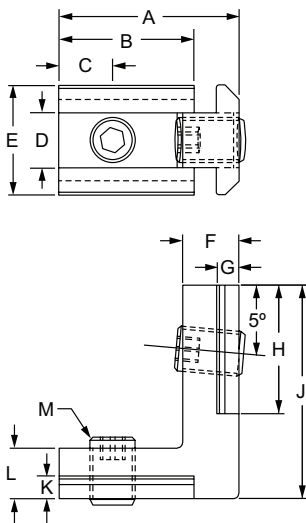

Inside-Inside Connector

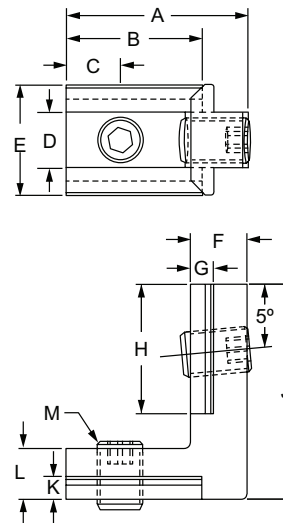

Inside-Outside Connector



Part No.	Series	Type	Material	A	B	C	D	E	F	G	H	J	K	L	M	Weight	Price
33440	10 25	Inside-Inside	Zinc	.700"	.623"	.200"	.238"	.480"	.258"	.185"	.641"	1.000"	.185"	.258"	M5 x 0.8	.028 lb	\$4.35 ea.
33460		Inside-Outside		.700"	.623"	.200"	.238"	.480"	.258"	.185"	.641"	1.000"	.185"	.258"	M5 x 0.8	.028 lb	\$4.35 ea.

Panel Machining Services

Machining Type	New Products Page
Hidden Corner Connector Clearance Notch	27

Hidden Corner Connector Assembly

Inside-Outside Connector Shown

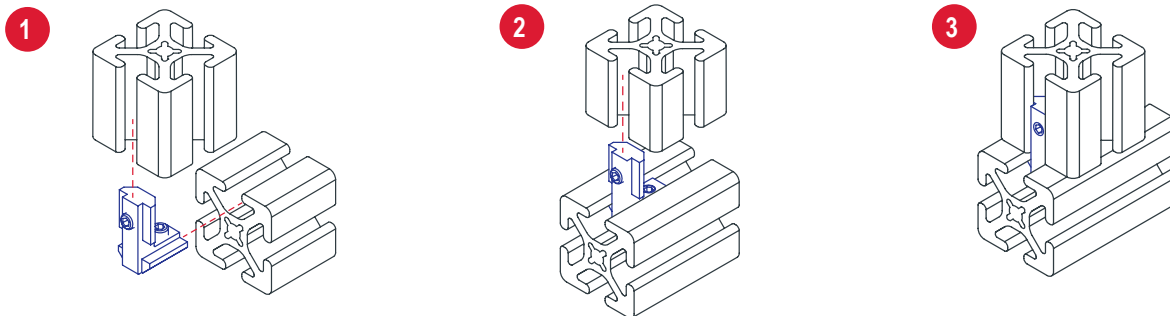

NEW

Products 2018

80/20® Inc.

The **Industrial Erector Set**®

Central Connector

The central connector is an assembly comprised of a cam, conical set screw, and T-stud. It is a strong internal fastening method, offering a long-lasting connection. The central connector can be used when profile ends are captivated and it provides infinite positioning along the mating profile's T-slot, allowing a large degree of adjustability. The central connector is a 90 degree, hidden, aesthetic connection. This connection requires a central connector profile milling machining service. The 30 series central connector has an o-ring that bites into the profile center hole to retain the connector.

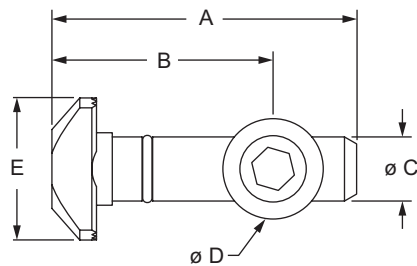

Horizontal

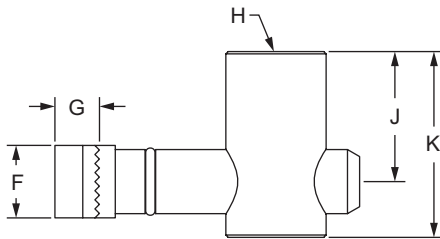
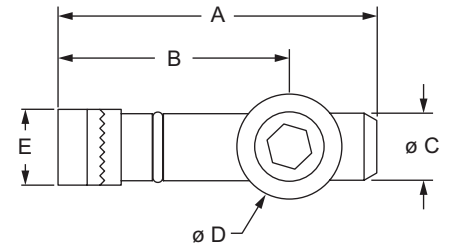

Vertical

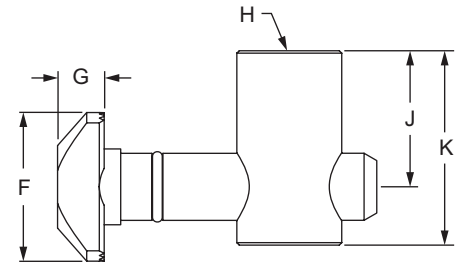

Part No.	Series	Orientation	Material	A	B	C	D	E	F	G	H	J	K	Weight	Price
13194	30	Vertical	Steel	32.80mm	23.80mm	6.90mm	10.80mm	7.80mm	15.30mm	4.80mm	M8 X 10mm	14.00mm	20.00mm	.0426 kg	\$4.55 ea.
13195		Horizontal		32.80mm	23.80mm	6.90mm	10.80mm	7.80mm	15.30mm	4.80mm	M8 X 10mm	14.00mm	20.00mm	.0426 kg	\$4.55 ea.

Required Machining Services

Machining Type	Profile Machined	New Products Page
Central Connector Profile Milling	Mounting Profile	25

Panel Machining Services

Machining Type	New Products Page
Central Connector Clearance Notch	26

Central Connector Assembly

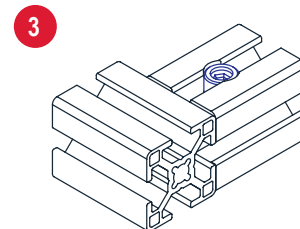
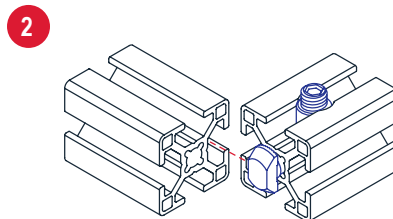
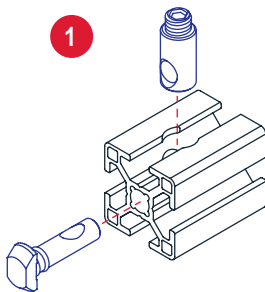

NEW

Products 2018

80/20® Inc.The **Industrial Erector Set®**

2 Way - Light Squared Corner Connector

The 2 way - light squared corner connector is a die-cast external fastening method that is typically used to create a squared corner connection between two profiles. The fastener is lightweight and has two access holes; it includes the cover caps for the holes, to provide a finished look. The 2 way - light squared corner connector requires an end tap machining service (see Catalog 22 page 853) on the mating profiles.

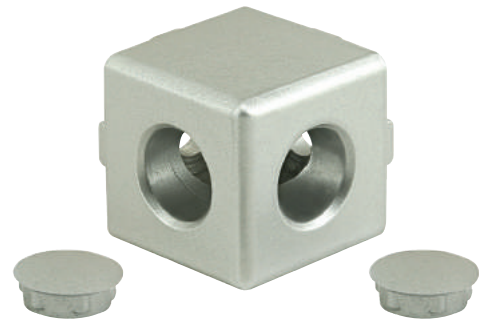
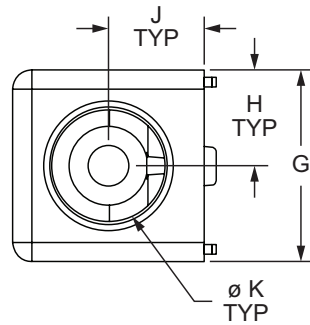
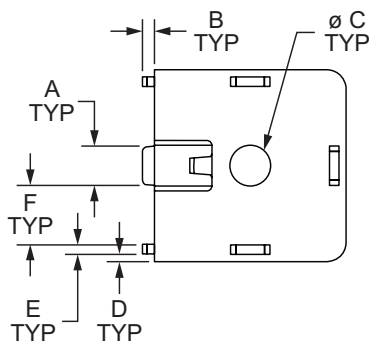

Part No.	Series	Material	Finish	A	B	C	D	E	F	G	H	J	K	Weight	Price
14154	10 25	Aluminum	Lacquered	.244"	.098"	.283"	.039"	.079"	.256"	.992"	.496"	.496"	.470"	.110 lb	\$7.38 ea.

Required Machining Services

Machining Type	Profile Machined	Catalog 22 Page
Tap Profile End	Mounting Profile	853

Suggested Hardware (Mount to Profile End)

Part No.	Series	Qty.	Bolt
3063	10	2	1/4-20 x 5/8" BHSCS
11-6316	25	2	M6 x 16mm BHSCS

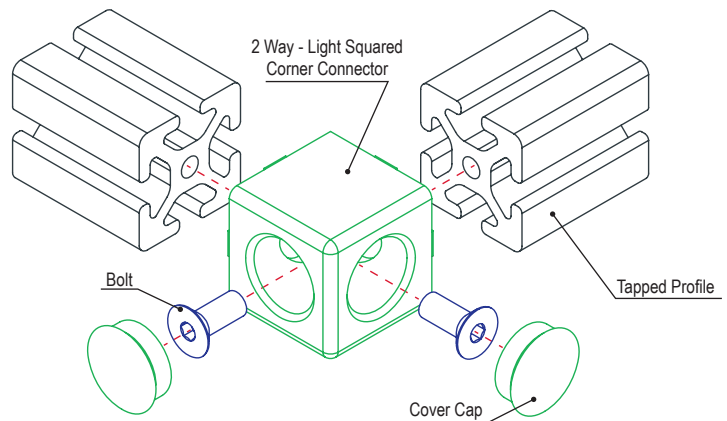

NEW

Products 2018

80/20® Inc.The **Industrial Erector Set®**

3 Way - Light Squared Corner Connector

The 3 way - light squared corner connector is a die-cast external fastening method that is typically used to create a squared corner connection between three profiles. The fastener is lightweight and has three access holes; it includes the cover caps for the holes, to provide a finished look. The 3 way - light squared corner connector requires an end tap machining service (see Catalog 22 page 853) on the mating profiles.

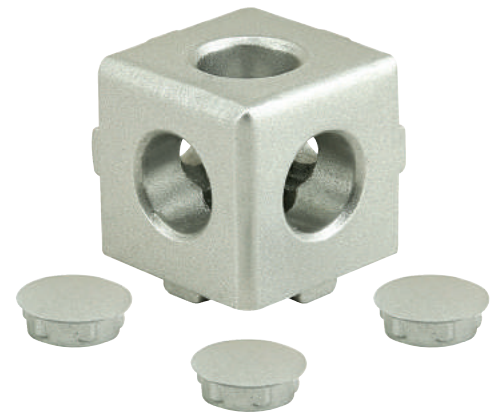
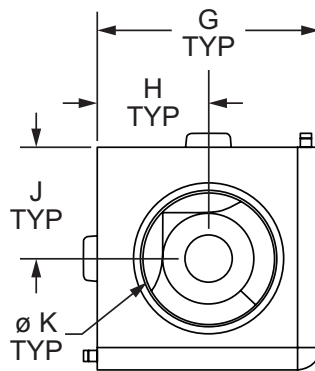
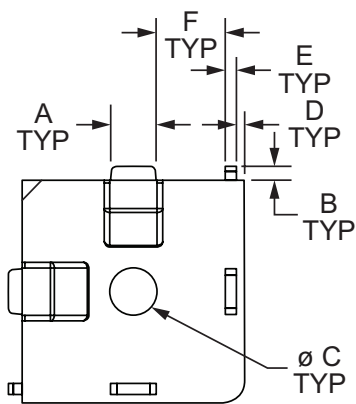

Part No.	Series	Material	Finish	A	B	C	D	E	F	G	H	J	K	Weight	Price
14135	10 25	Aluminum	Lacquered	.244"	.098"	.283"	.039"	.079"	.256"	.992"	.496"	.496"	.470"	.090 lb	\$9.10 ea.

Required Machining Services

Machining Type	Profile Machined	Catalog 22 Page
Tap Profile End	Mounting Profile	853

Suggested Hardware (Mount to Profile End)

Part No.	Series	Qty.	Bolt
3063	10	3	1/4-20 x 5/8" BHSCS
11-6316	25	3	M6 x 16mm BHSCS

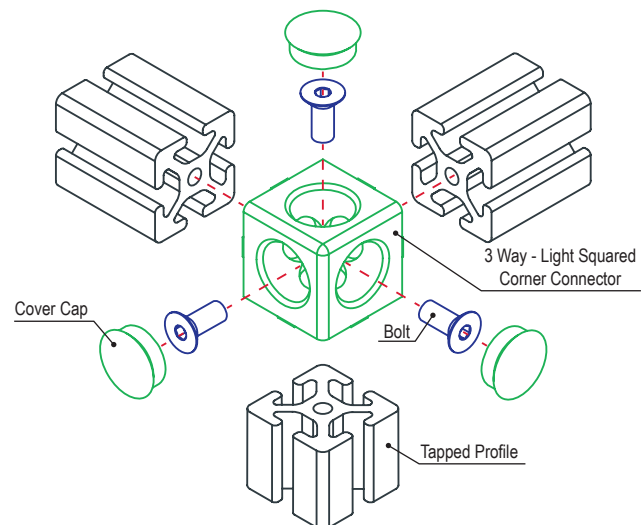

NEW

Products 2018

80/20® Inc.The **Industrial Erector Set®**

High-Capacity Swivel Caster

The high-capacity swivel caster is a foot that adds mobility to an application and commonly mounts to the T-slot profile end or side using a base plate. It is made for higher loads and provides smooth rolling movement, enabling easy turns. The polyurethane wheel is resistant to machining chips from the floor. The wheel has a capacity of up to 1000 pounds (453.59 kilograms), making it ideal for use in industrial settings such as mobile carts and material handling solutions. For base plate options see Catalog 22 pages 629-652.

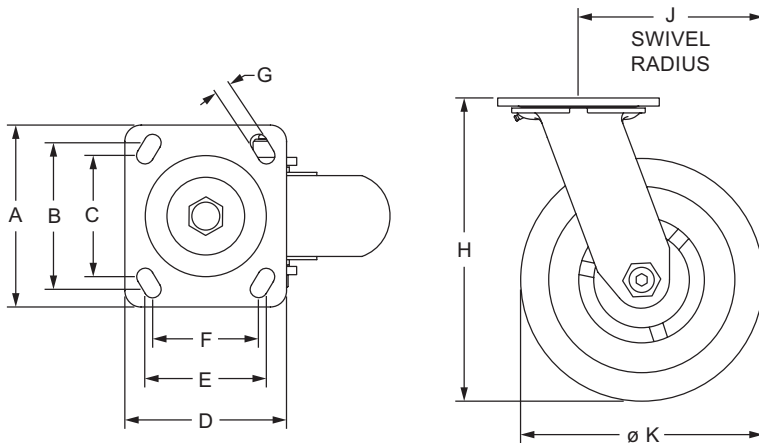

Part No.	Series	Material	A	B	C	D	E	F	G	H	J	K	Load Capacity	Weight	Price
2703	15 40	Steel / Polyurethane	4.500"	3.625"	3.000"	4.000"	3.000"	2.625"	.420"	7.500"	4.562"	6.000"	1000 lb	5.727 lb	\$63.55 ea.

Suggested Hardware (Mount to Base Plate)

Part No.	Series	Qty.	Bolt
3125	15	4	3/8-16 x 3/4" SHCS
13-1520	40	4	M10 x 20mm SHCS

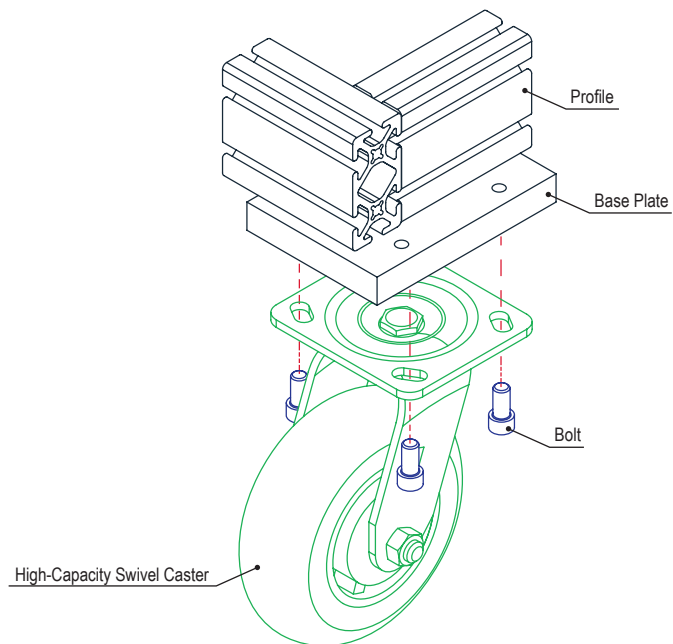

NEW

Products 2018

80/20® Inc.The **Industrial Erector Set®**

High-Capacity Rigid Caster

The high capacity rigid caster is a foot that adds mobility to an application and commonly mounts to the T-slot profile end or side using a base plate. It can be used for higher loads and has a capacity of up to 1000 pounds (453.59 kilograms), making it ideal for use in industrial settings such as mobile carts and material handling solutions. The polyurethane wheel is resistant to machining chips from the floor. It is commonly used in conjunction with swivel casters to create applications that pivot easily. For base plate options see Catalog 22 pages 629-652.

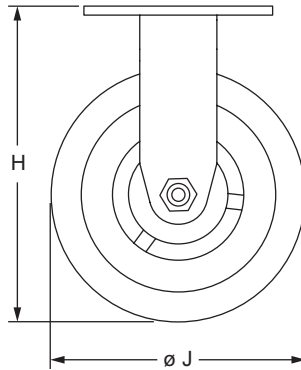
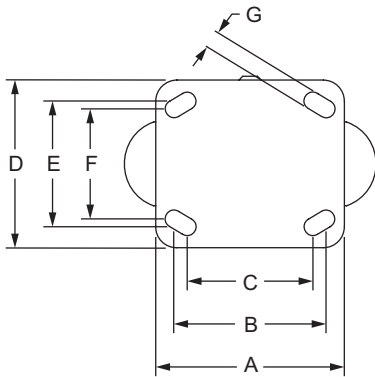
**NEW**

Part No.	Series	Material	A	B	C	D	E	F	G	H	J	Load Capacity	Weight	Price
2702	15 40	Steel / Polyurethane	4.500"	3.625"	3.000"	4.000"	3.000"	2.625"	.420"	7.500"	6.000"	1000 lb	5.009 lb	\$54.64 ea.

Suggested Hardware (Mount to Base Plate)

Part No.	Series	Qty.	Bolt
3125	15	4	3/8-16 x 3/4" SHCS
13-1520	40	4	M10 x 20mm SHCS

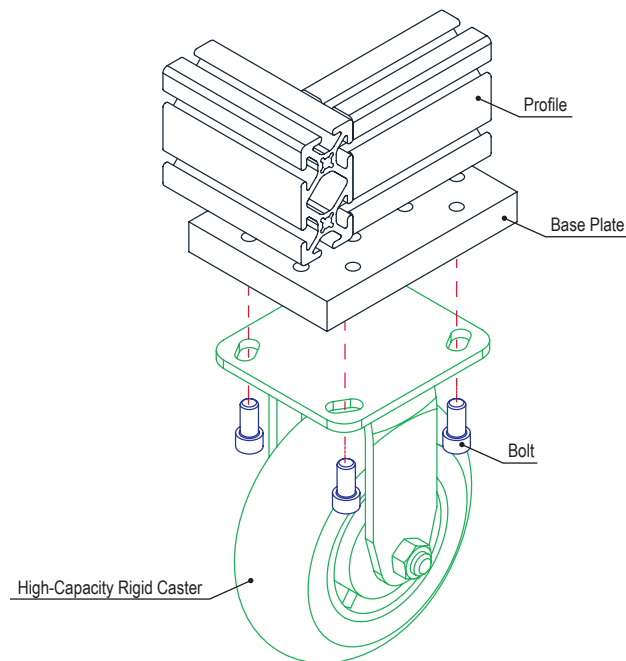

NEW

Products 2018

80/20® Inc.

The **Industrial Erector Set®**

Economy T-Slot Cover

The economy T-slot cover is a cost-effective way to add a finishing touch and polished look to an application. It prevents dust and debris build up and covers wires and tubes in the T-slot channel. **Tip:** Use a soft faced mallet (see Catalog 22 page 906) to tap the cover into the T-slot.

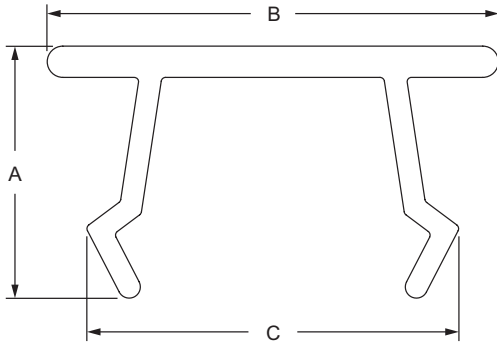

Part No.	Series	Material	Finish	Process	Color	A	B	C	Stock Length	Weight	Price
2871	15 40	PVC	Matte	Extruded	Clear	.283"	.505"	.416"	72.500"	.126 lb	\$3.45 ea.

NEW

Products 2018

80/20® Inc.

The **Industrial Erector Set**®

Wire Housing

Wire housing is commonly used to organize wires, cables, and tubes. It can be integrated into new or existing applications. The housing makes it easy to place and remove wires simply by removing the wire housing cover (see page 12). It has breakaway fingers that snap off to accommodate large wire groupings. The wire housing is available in gray or black.

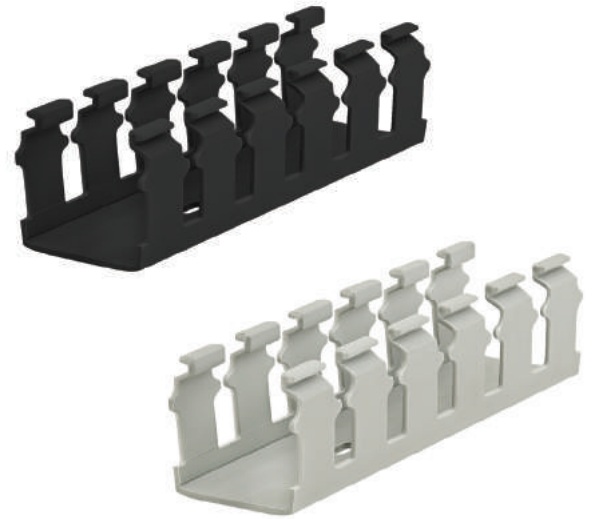
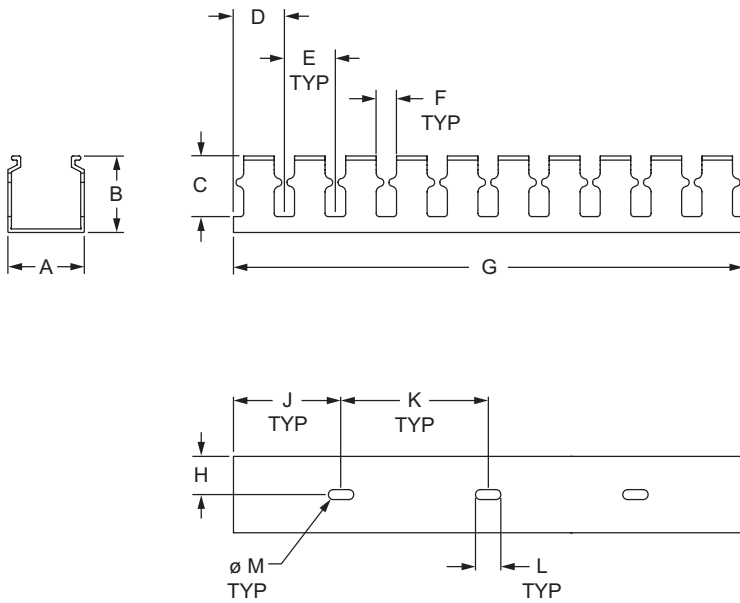

Part No.	Series	Material	Color	A	B	C	D	E	F	G	H	J	K	L	M	Weight	Price
13197	10 15	PVC	Black	1.500"	1.502"	1.190"	1.000"	1.000"	.400"	72.000"	.750"	2.000"	4.000"	.500"	.195"	.885 lb	\$41.00 ea.
13199	25 30 40 45		Gray	1.500"	1.502"	1.190"	1.000"	1.000"	.400"	72.000"	.750"	2.000"	4.000"	.500"	.195"	.945 lb	\$41.00 ea.

Suggested Hardware (Mount to T-Slot)

Series	Part No.	Qty.*	Bolt	Part No.	Qty.*	T-Nut
10	3042	1	10-32 x .375" BHSCS	3205	1	Slide-in
15	3050	1	10-32 x .500" BHSCS	3201	1	Slide-in
25	11-5310	1	M5 x 10mm BHSCS	25-1954	1	Slide-in
30	11-5312	1	M5 x 12mm BHSCS	13115	1	Drop-in
40	11-5312	1	M5 x 12mm BHSCS	3871	1	Slide-in
45	11-5316	1	M5 x 16mm BHSCS	13127	1	Drop-in

* Suggested hardware quantity is per hole. Stock length suggested quantity is 9, utilizing every other hole.

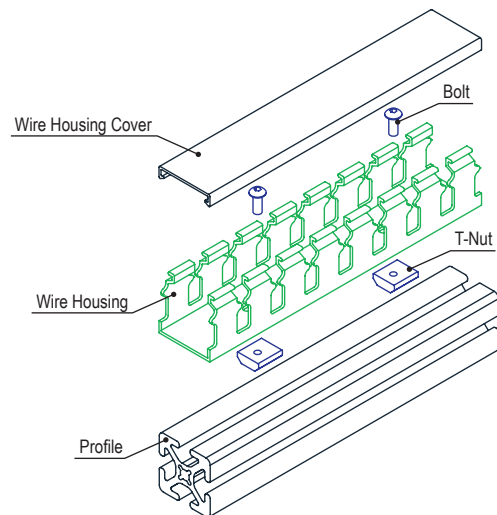

NEW

Products 2018

80/20® Inc.The **Industrial Erector Set®**

Wire Housing Cover

The wire housing cover is commonly used with the wire housing (see page 11) for wire and cable storage and organization. It keeps dirt and debris out while retaining wires in the housing. The wire housing cover is available in gray or black.

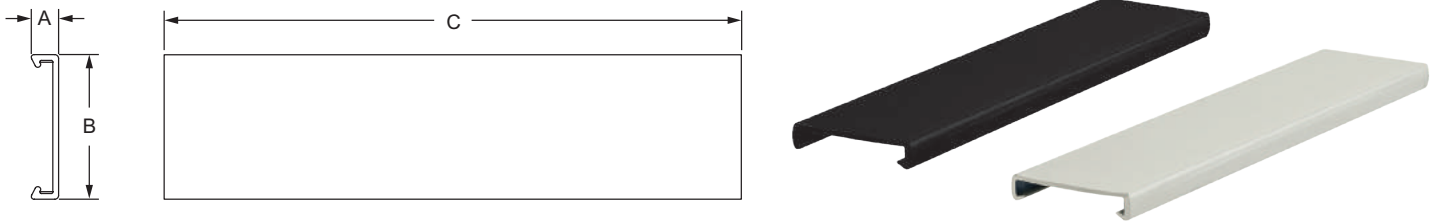

Part No.	Series	Material	Color	A	B	C	Weight	Price
13198	10 15	Rigid PVD Flexible PVC	Black	.283"	1.500"	72.000"	.385 lb	\$10.00 ea.
13200	25 30 40 45		Gray	.283"	1.500"	72.000"	.435 lb	\$10.00 ea.

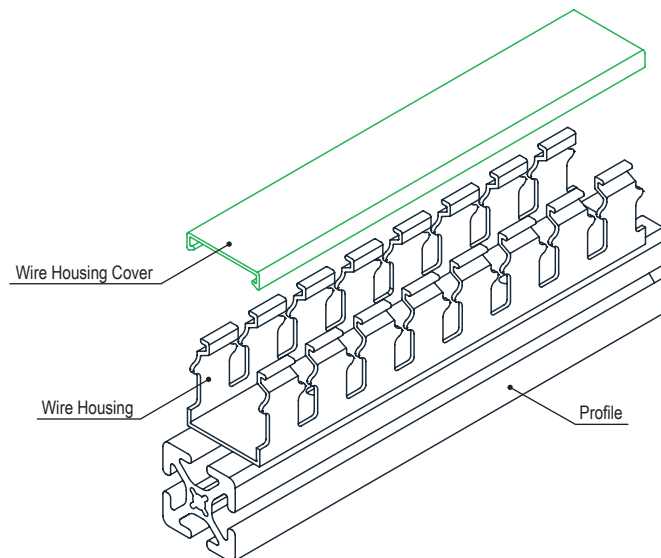

NEW

Products 2018

80/20® Inc.The **Industrial Erector Set®**

Vertical Mount Hook

The vertical mount hook can be used to provide storage and organization. It mounts vertically to a T-slot profile.

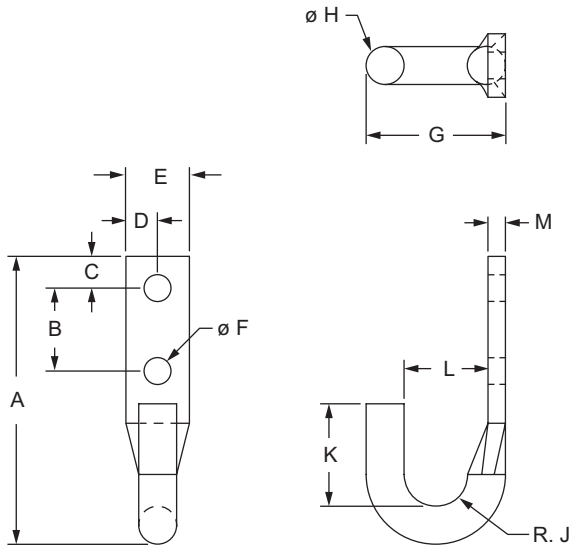

Part No.	Series	Material	A	B	C	D	E	F	G	H	J	K	L	M	Weight	Price
14158	10 15 25 30 40 45	Steel	2.810"	.810"	.310"	.310"	.620"	.260"	1.360"	.370"	.310"	1.000"	.820"	.170"	.290 lb	\$3.25 ea.

Suggested Hardware (Mount to T-Slot)

Series	Part No.	Qty.	Bolt	Part No.	Qty.	T-Nut
10	3061	2	1/4-20 x .500" BHSCS	3376	2	Roll-in
15	3063	2	1/4-20 x .625" BHSCS	14165	2	Drop-in
25	11-6312	2	M6 x 12mm BHSCS	25-1966	2	Roll-in
30	11-6312	2	M6 x 12mm BHSCS	13117	2	Drop-in
40	11-6314	2	M6 x 14mm BHSCS	13119	2	Drop-in
45	11-6316	2	M6 x 16mm BHSCS	13129	2	Drop-in

NEW

Products 2018

80/20® Inc.The **Industrial Erector Set®**

Horizontal Mount Hook

The horizontal mount hook can be used to provide storage and organization. It mounts horizontally to a T-slot profile.

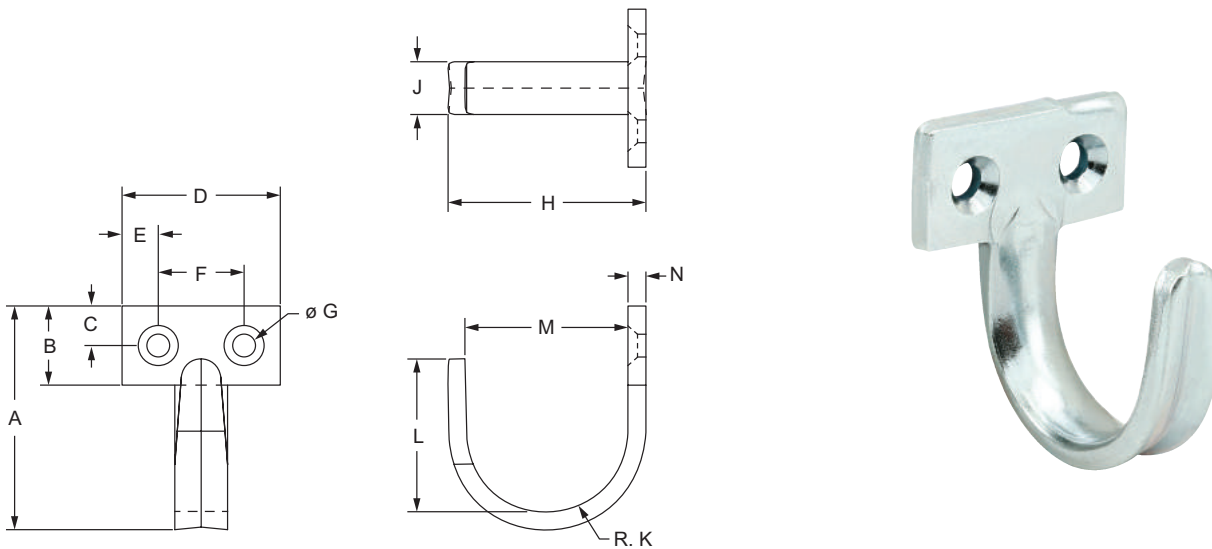
**NEW**

Part No.	Series	Material	A	B	C	D	E	F	G	H	J	K	L	M	N	Weight	Price
14155	10 15 25 30 40 45	Steel	1.859"	.750"	.375"	1.510"	.349"	.813"	.203"	1.631"	.500"	.562"	1.260"	1.305"	.179"	.210 lb	\$3.15 ea.

Suggested Hardware (Mount to T-Slot)

Series	Part No.	Qty.	Bolt	Part No.	Qty.	T-Nut
10	3050	2	10-32 x .500" BHSCS	3375	2	Roll-in
15	3051	2	10-32 x .625" BHSCS	3932	2	Drop-in
25	11-5312	2	M5 x 12mm BHSCS	25-1956	2	Roll-in
30	11-5312	2	M5 x 12mm BHSCS	13115	2	Drop-in
40	11-5314	2	M5 x 14mm BHSCS	13116	2	Drop-in
45	11-5316	2	M5 x 16mm BHSCS	13127	2	Drop-in

NEW

Products 2018

80/20® Inc.

The **Industrial Erector Set**®

Heavy Duty Monitor Mount

The heavy duty monitor mount aids ergonomic initiatives and keeps the monitor off the work surface. It is compatible with the Video Electronics Standards Association (VESA) mounting patterns of 100x100, 200x100, or 200x200, which includes most 23" to 42" displays. The mount supports adjustments in three dimensions; it can rotate 360 degrees, tilt ranging from 15 degrees upward to 15 degrees downward, and swivel ± 90 degrees. Additionally, it can be extended from the mounting surface a minimum distance of 3.82 inches (97mm) to a maximum of 16.65 inches (423mm). The mount can safely hold up to 44 pounds (20 kg).

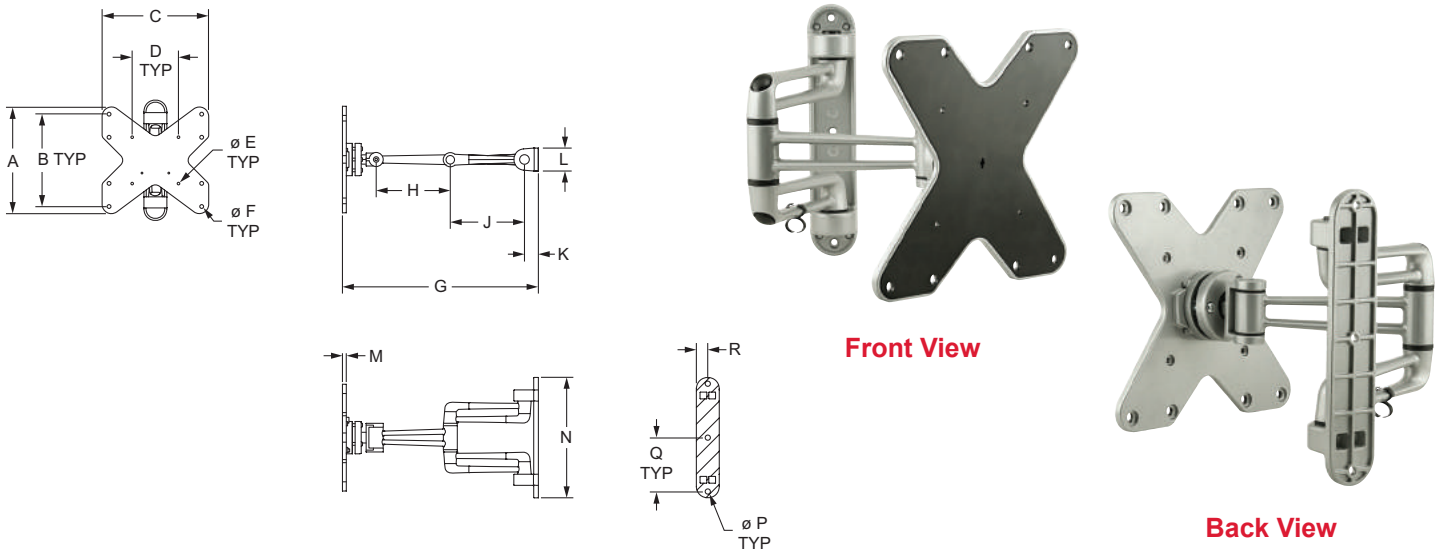

Part No.	Series	A	B	C	D	E	F	G	H	J
2285	15 40 45	9.075" (230.50mm)	7.874" (200.00mm)	9.055" (230.00mm)	3.937" (100.00mm)	.213" (5.41mm)	.331" (8.41mm)	16.654" (423.01mm)	6.299" (160.00mm)	6.299" (160.00mm)
		K	L	M	N	P	Q	R	Weight	Price
2285	15 40 45	1.181" (30.00mm)	1.950" (49.53mm)	.331" (8.41mm)	10.236" (260.00mm)	.236" (6.00mm)	4.579" (116.31mm)	.974" (24.74mm)	4.467 lb (2.0262 kg)	\$90.97 ea.

Material Specifications

Material	Finish	Color
Zinc	Powder Coat	Aluminum Silver

Suggested Hardware (Mount to T-Slot)

Series	Part No.	Qty.	Bolt	Part No.	Qty.	T-Nut
15	13-6316	3	M6 x 16mm BHSCS	3836	3	Slide-in
40	13-6316	3	M6 x 16mm BHSCS	40-1961	3	Slide-in
45	13-6316	3	M6 x 16mm BHSCS	13130	3	Drop-in

NEW

Products 2018

80/20® Inc.The **Industrial Erector Set®**

Magnetic Tool Holder

The magnetic tool holder is commonly used to organize and store tools. It mounts to a T-slot profile.

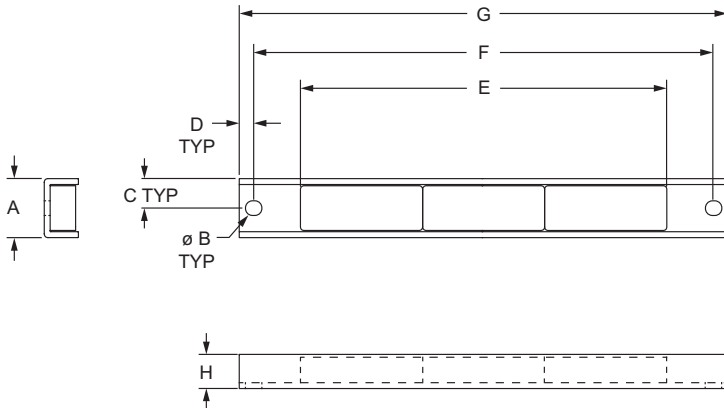

Part No.	Series	Material	Color	A	B	C	D	E	F	G	H	Weight	Price
3959	10 15 25 30 40 45	Steel	Black	.950"	.236"	.475"	.233"	21.654"	23.160"	23.625"	.550"	2.062 lb	\$19.90 ea.

Suggested Hardware (Mount to T-Slot)

Series	Part No.	Qty.	Bolt	Part No.	Qty.	T-Nut
10	11-6312	2	M6 x 12mm BHSCS	3859	2	Slide-in
15	11-6312	2	M6 x 12mm BHSCS	3931	2	Drop-in
25	11-6310	2	M6 x 10mm BHSCS	25-1961	2	Slide-in
30	11-6310	2	M6 x 10mm BHSCS	13117	2	Drop-in
40	11-6312	2	M6 x 12mm BHSCS	40-1961	2	Slide-in
45	11-6312	2	M6 x 12mm BHSCS	13129	2	Drop-in

NEW

Products 2018

80/20® Inc.

The **Industrial Erector Set®**

3M™ VHB™ Tape

3M™ VHB™ tape is a high-strength bonding method that is easy to use and provides long-term durability. The double-sided tape adheres to a wide variety of materials and is commonly used to mount a work surface, as it eliminates the need for machining. The pressure-sensitive adhesive bonds on contact. **Additional Information:** Please note this product is sold in packs of 10 pieces.

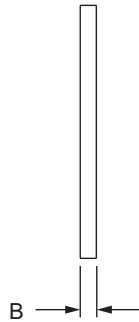

Part No.	Series	Material	Color	A	B	Weight	Price
13099	F M	Acrylic	White	1.181" (30.00mm)	.039" (1.00mm)	.023 lb (.0104 kg)	\$6.25 / pack

NEW

Products 2018

80/20® Inc.

The **Industrial Erector Set**®

3 Slot Mount - Double Flange Short High-Cycle Linear Bearing with Brake Holes

The 3 slot mount – double flange short high-cycle linear bearing with brake holes is typically used in linear motion applications. It contains special threaded inserts in the pads which provide a heavy-duty bearing capable of withstanding repetitive cycles with sudden acceleration and deceleration. The bearing houses profiles with a minimum of three open T-slots, has a double flange and is a shorter option. The pads, screws and shims are included; the pads are made of self-lubricating UHMW. All 80/20 bearings are designed for compression loads only and not intended to support hanging loads.



Clear Anodized

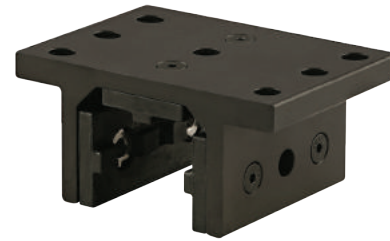

Black Anodized

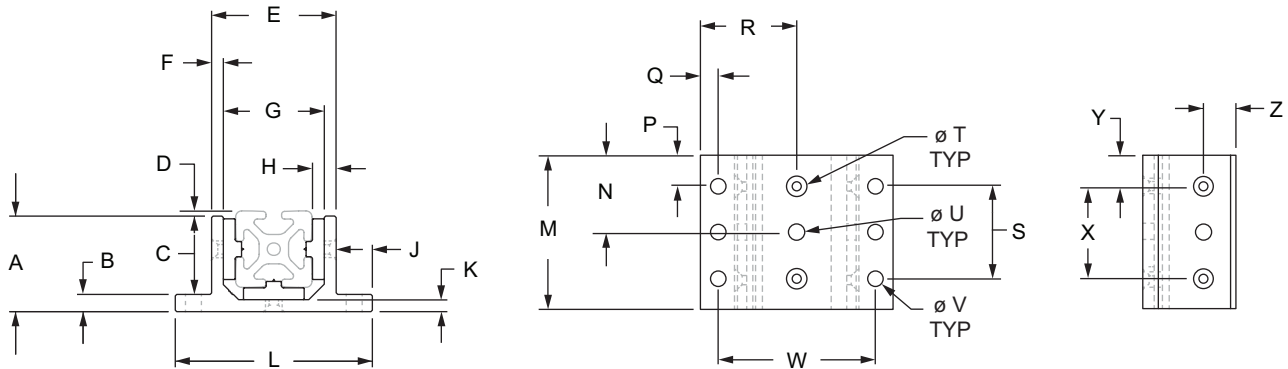

Part No.	Series	Color	A	B	C	D	E	F	G	H	J	K	L	M
45-6525	45	Clear	56.40mm	9.50mm	46.90mm	2.02mm	70.44mm	6.40mm	57.64mm	12.57mm	24.78mm	7.10mm	120.00mm	80.00mm
45-6525-Black	45	Black	56.40mm	9.50mm	46.90mm	2.02mm	70.44mm	6.40mm	57.64mm	12.57mm	24.78mm	7.10mm	120.00mm	80.00mm
	N	P	Q	R	S	T	U	V	W	X	Y	Z	Weight	Price
45-6525	40.00mm	17.50mm	15.00mm	60.00mm	45.00mm	#10 FHSCS	8.74mm	8.33mm	90.00mm	45.00mm	17.50mm	20.48mm	.4073 kg	\$53.70 ea.
45-6525-Black	40.00mm	17.50mm	15.00mm	60.00mm	45.00mm	#10 FHSCS	8.74mm	8.33mm	90.00mm	45.00mm	17.50mm	20.48mm	.4073 kg	\$56.89 ea.

Material Specifications

Material	Alloy*	Process	Finish
Aluminum	6005A-T61	Extrude	Anodize

* Or comparable

NEW

Products 2018

80/20® Inc.The **Industrial Erector Set®**

3 Slot Mount - Double Flange Long High-Cycle Linear Bearing with Brake Holes

The 3 slot mount – double flange long high-cycle linear bearing with brake holes is typically used in linear motion applications. It contains special threaded inserts in the pads which provide a heavy-duty bearing capable of withstanding repetitive cycles with sudden acceleration and deceleration. The bearing houses profiles with a minimum of three open T-slots, has a double flange and is a longer option. The pads, screws and shims are included; the pads are made of self-lubricating UHMW. All 80/20 bearings are designed for compression loads only and not intended to support hanging loads.

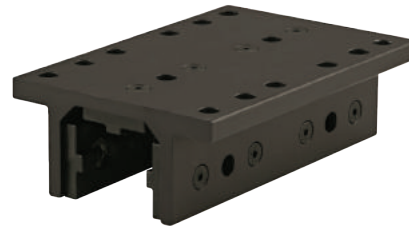
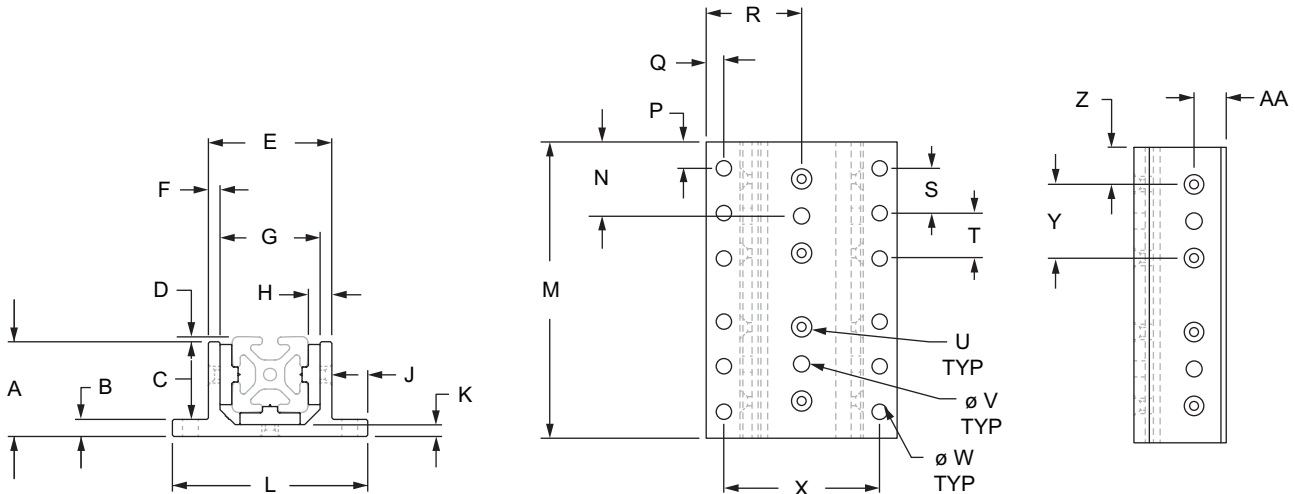
**Clear Anodized****Black Anodized**

Part No.	Series	Color	A	B	C	D	E	F	G	H	J	K	L	M	N	
45-6526	45	Clear	56.40mm	9.50mm	46.90mm	2.02mm	70.44mm	6.40mm	57.64mm	12.57mm	24.78mm	7.10mm	120.00mm	170.00mm	40.00mm	
45-6526-Black	45	Black	56.40mm	9.50mm	46.90mm	2.02mm	70.44mm	6.40mm	57.64mm	12.57mm	24.78mm	7.10mm	120.00mm	170.00mm	40.00mm	
			P	Q	R	S	T	U	V	W	X	Y	Z	AA	Weight	Price
45-6526	45		17.50mm	15.00mm	60.00mm	45.00mm	45.00mm	#10 FHSCS	8.74mm	8.33mm	90.00mm	45.00mm	17.50mm	20.48mm	.8587 kg	\$68.75 ea.
45-6526-Black	45		17.50mm	15.00mm	60.00mm	45.00mm	45.00mm	#10 FHSCS	8.74mm	8.33mm	90.00mm	45.00mm	17.50mm	20.48mm	.8587 kg	\$73.80 ea.

Material Specifications

Material	Alloy*	Process	Finish
Aluminum	6005A-T61	Extrude	Anodize

* Or comparable

NEW

Products 2018

80/20® Inc.The **Industrial Erector Set®**

Single-Keyed Standard Linear Bearing Pad

The single-keyed standard linear bearing pad is commonly used with bearings to create linear motion and is made of self-lubricating UHMW. It has a low coefficient of friction and is designed with rounded corners on the molded pad, allowing simple installation and replacement. This pad has a single key and mounts to the housing using steel flathead socket cap screws that have Loctite®. It comes with holes for mounting hardware or brake kits and includes nutserts.

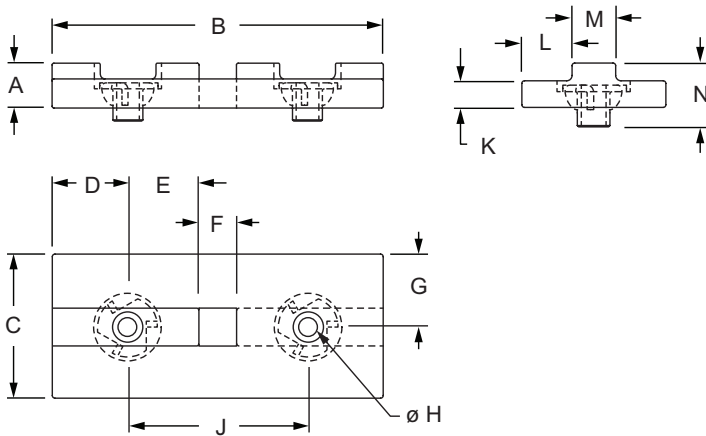

Part No.	Series	A	B	C	D	E	F	G	H	J	K	L	M	N	Weight	Price
45-6598	45	10.77mm	78.00mm	39.00mm	16.50mm	17.50mm	10.00mm	19.50mm	10-32	45.00mm	6.17mm	14.63mm	9.75mm	12.29mm	.0168 kg	\$3.09 ea.

Material Specifications

Part No.	Material	Process	Finish	Color
45-6598	UHMW PE	Injection Mold	Smooth	Black

Suggested Hardware (Mount Pad to Bearing Housing)

Part No.	Series	Qty.	Bolt
3022	45	2	10-32 x 1/2" FHSCS

NEW

Products 2018

80/20® Inc.

The **Industrial Erector Set®**

Linear Bearing Shim Stock

Linear bearing shim stock is used to create a precise fit. Each shim is .005" (.127mm) thick and has a slotted design that enables easy installation without having to dismantle the bearing; simply loosen the bearing pad and slide the shim(s) between the pad and housing while the bearing is still in place. Shims are sold in packs of 10. See Catalog 22 page 658 for more information on shims.

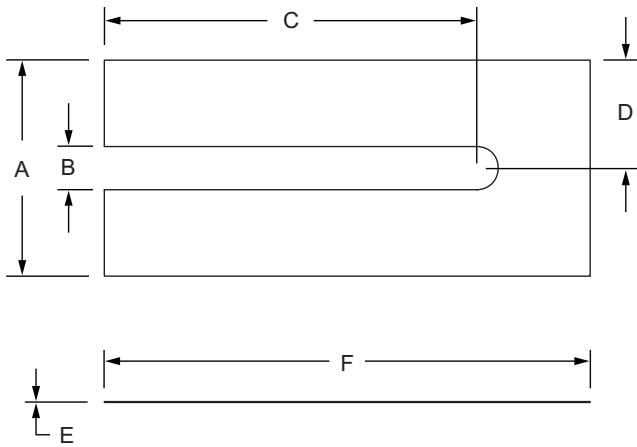

Part No.	Series	Material	Process	Color	A	B	C	D	E	F	Weight	Price
45-6880	45	Mylar	Cut	Clear	36.00mm	8.00mm	66.50mm	18.00mm	.08mm	80.00mm	.0036 kg	\$5.07 / pack

NEW

Products 2018

80/20® Inc.

The **Industrial Erector Set®**

“L” Handle Linear Bearing Brake Kit

The “L” handle linear bearing brake kit adds an adjustable stop to any brake-ready bearing by securing it into a semi-permanent position. It also adds a grip to aid with adjustments and provides secure lockdown capability for safety. All mounting hardware is included.

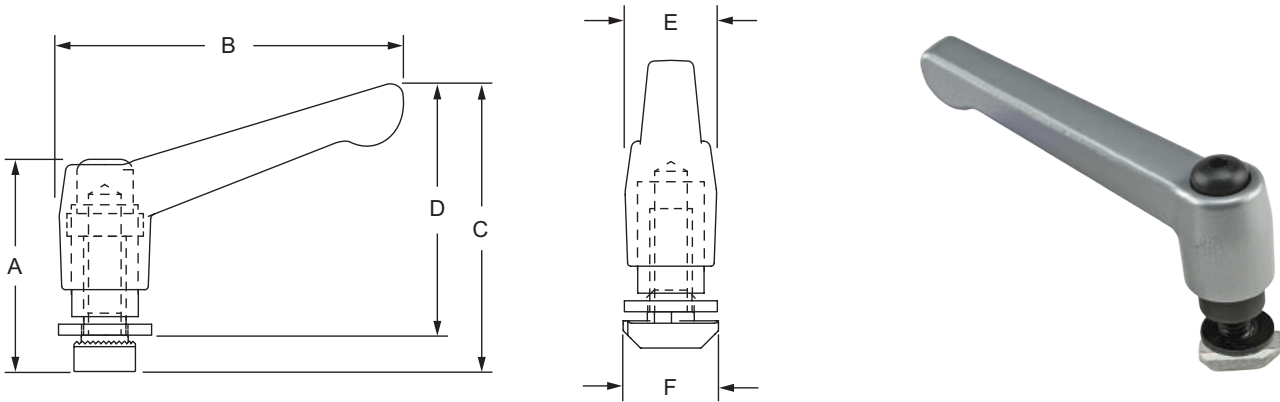

Part No.	Series	Material	Process	Finish	Color	A	B	C	D	E	F	Weight	Price
45-6800	45	Zinc	Die Cast	Gloss	Gray	56.74mm	89.03mm	75.82mm	56.77mm	22.12mm	19.00mm	.1524 kg	\$13.75

NEW

Products 2018

80/20® Inc.The **Industrial Erector Set®**

Double Flange Bearing Profile

The double flange bearing profile can be cut to your desired length. There are options available in a mill or anodize finish. It is commonly used in custom linear motion applications. See Catalog 22 page 852 for the cut-to-length machining service.

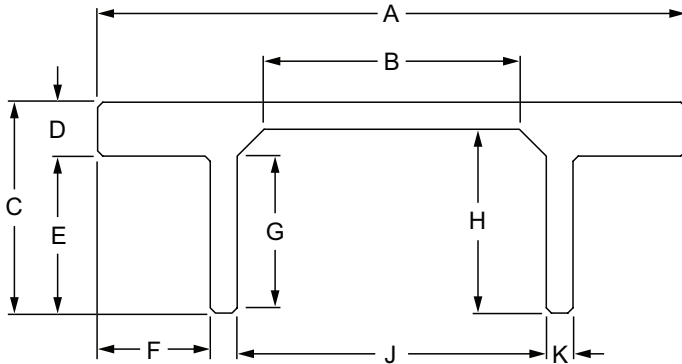

Part No.	Series	A	B	C	D	E	F	G	H	J	K	Stock Length	Weight	Price
45-8536*	45	120.00mm	40.00mm	56.40mm	9.50mm	46.90mm	24.78mm	40.48mm	49.30mm	57.64mm	6.40mm	Per millimeter	.0094 kg / mm	\$0.0550 / mm
45-8537												Per millimeter	.0094 kg / mm	\$0.0437 / mm
45-8537-Black*												Per millimeter	.0094 kg / mm	\$0.0680 / mm
45-8537-4M												4M	37.70 kg	\$174.83

* Longer lead times apply

Material Specifications

Part No.	Material	Alloy*	Finish	Process
45-8536	Aluminum	6005A-T61	Clear Anodize	Extruded
45-8537			Natural Mill	
45-8537-Black			Black Anodize	
45-8537-4M			Natural Mill	

* Or comparable

NEW

Products 2018

80/20® Inc.

The **Industrial Erector Set®**

Six Lobe Tools



6072



6064



6074

Part No.	Series	Bit Size	Weight	Price
6064	F M	Six Lobe "L" Wrench - T-27	.042 lb	\$2.58 ea.
6074	F M	Six Lobe "T" Handle Wrench - T-27	.300 lb	\$8.67 ea.
6072	F M	Six Lobe Power Bit - T-27	.033 lb	\$2.68 ea.

NEW

Products 2018

80/20® Inc.

The **Industrial Erector Set**®

Central Connector Profile Milling

The central connector profile milling service consists of both a drill through the profile end and a T-slot counterbore. This milling service enables the use of a central connector; see page 5 for more information on central connectors. **Additional Information:** When ordering this milling service, designate profile end (left, right or both) and T-slot for the counterbore.

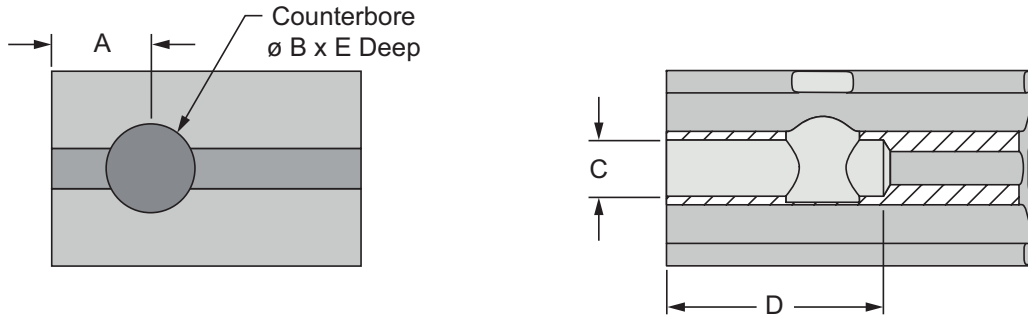

Part No.	Series	Service Type	A	B	C	D	E	Price
7058	15	15 Series Profile Milling for Central Connector	1.260"	.597"	.453"	1.750"	1.025"	\$4.20 ea.
30-7058	30	30 Series Profile Milling for Central Connector	17.50mm	11.11mm	8.03mm	30.50mm	21.34mm	\$4.20 ea.
40-7058	40	40 Series Profile Milling for Central Connector	32.00mm	15.16mm	11.51mm	44.45mm	26.97mm	\$4.20 ea.
45-7058	45	45 Series Profile Milling for Central Connector	22.50mm	17.12mm	—	—	32.64mm	\$4.20 ea.

Central Connector Machining Designations

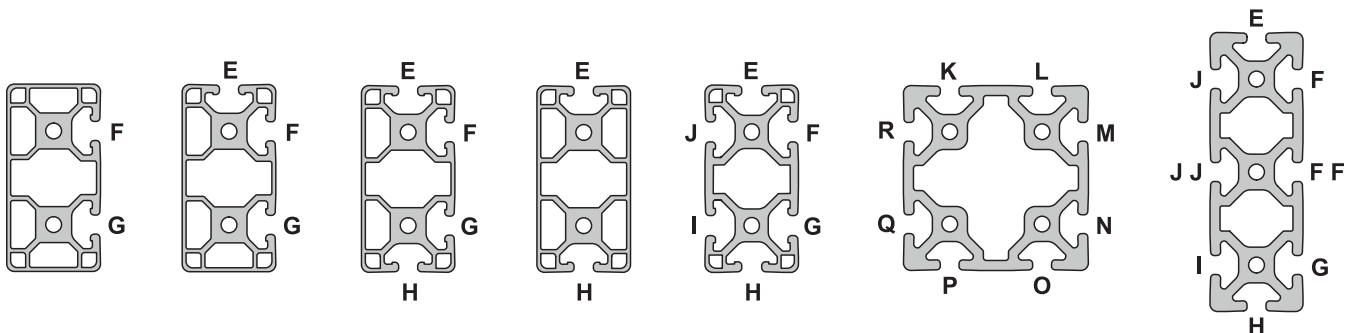
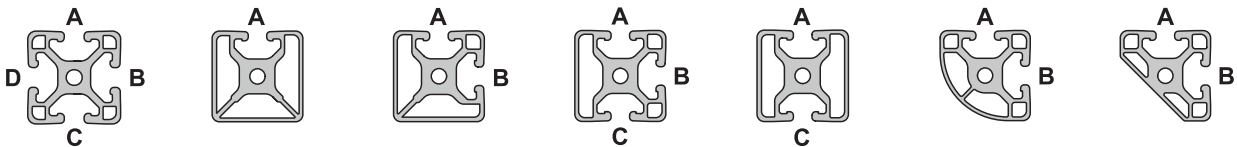



Central Connector Clearance Notch

The central connector clearance notch is used to clear a central connector when a panel will mount inside a T-slot. This notch is used on mesh, plastic panels and aluminum up to .250" (6.35mm) thick. See page 5 for more information on central connectors. **Additional Information:** When ordering this service, specify a vertical or horizontal orientation.

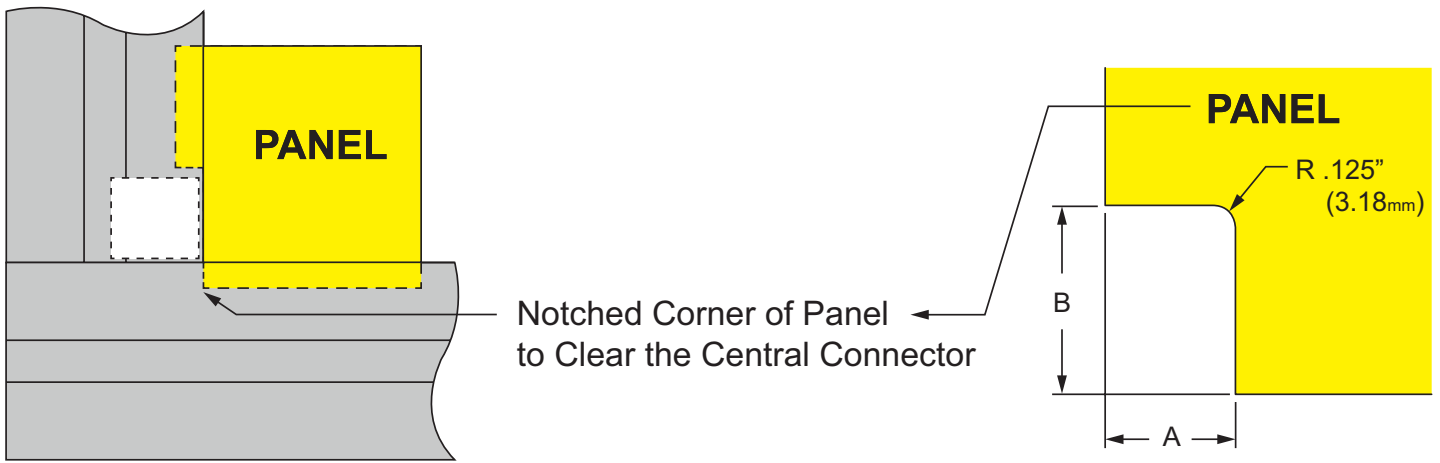

Panel & Wire Part No.	Aluminum Part No.	Series	Service Type	A	B	Cut Tolerance	Price
7320	7204	15	15 Series Corner Notch	.500"	2.000"	+/- .060"	\$1.05 ea.
NEW 30-7320	30-7204	30	30 Series Corner Notch	8.50mm	31.50mm	+/- 1.52mm	\$1.05 ea.
40-7320	40-7204	40	40 Series Corner Notch	12.70mm	50.80mm	+/- 1.52mm	\$1.05 ea.
45-7320	45-7204	45	45 Series Corner Notch	14.00mm	46.00mm		\$1.05 ea.

Ordering Example:
2609 (1) @ (AD) 23.000" x (AB) 28.000"
w/7320 Vertical on Corner B

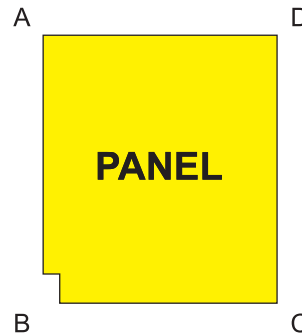

NEW

Products 2018

80/20® Inc.

The **Industrial Erector Set**®

Hidden Corner Connector Clearance Notch

The hidden corner connector clearance notch is used to clear a hidden corner connector when a panel will mount inside a T-slot. See page 4 for more information on hidden corner connectors. Two styles are available; one for the inside to inside corner connector and one for the inside to outside corner connector. **Additional Information:** When ordering this machining service for inside to outside hidden corner connector, specify a vertical or horizontal orientation.

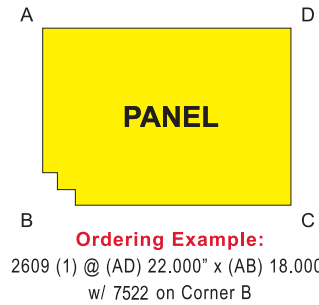
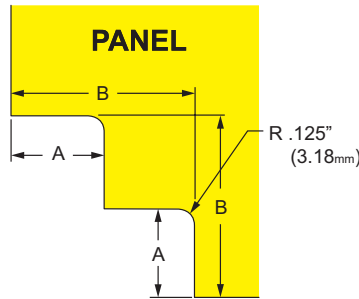
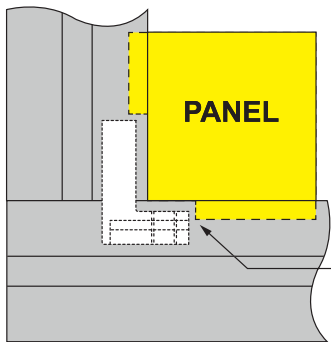

Inside to Inside: 7422, 7522, 25-7422, 30-7522, 40-7522, 45-7522

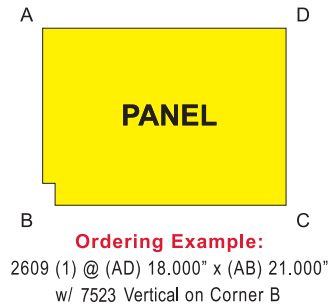
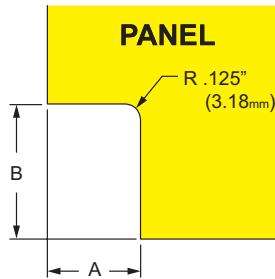
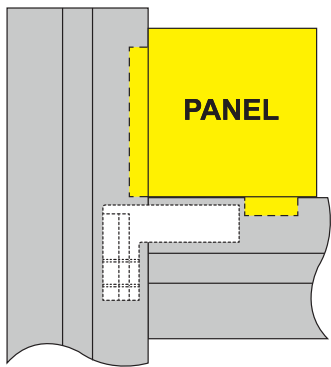

Inside to Outside: 7423, 7523, 25-7423, 30-7523, 40-7523, 45-7523

Panel & Wire Part No.	Series	Service Type	Connector Part No.	A	B	Cut Tolerance	Price
7422	10	Corner Notch for Inside to Inside Hidden Connector	33440	.315"	1.063"	+/- .060"	\$2.10 ea.
7423	10	Corner Notch for Inside to Outside Hidden Connector	33460	.315"	1.063"		\$2.10 ea.
7522	15	Corner Notch for Inside to Inside Hidden Connector	33450	.405"	1.263"	+/- .060"	\$2.10 ea.
7523	15	Corner Notch for Inside to Outside Hidden Connector	33470	.405"	1.263"		\$2.10 ea.
25-7422	25	Corner Notch for Inside to Inside Hidden Connector	33440	8.00mm	27.00mm	+/- 1.52mm	\$2.10 ea.
25-7423	25	Corner Notch for Inside to Outside Hidden Connector	33460	8.00mm	27.00mm		\$2.10 ea.
30-7522	30	Corner Notch for Inside to Inside Hidden Connector	33450	8.25mm	30.04mm	+/- 1.52mm	\$2.10 ea.
30-7523	30	Corner Notch for Inside to Outside Hidden Connector	33470	8.25mm	30.04mm		\$2.10 ea.
40-7522	40	Corner Notch for Inside to Inside Hidden Connector	33450	11.76mm	33.55mm		\$2.10 ea.
40-7523	40	Corner Notch for Inside to Outside Hidden Connector	33470	11.76mm	33.55mm		\$2.10 ea.
45-7522	45	Corner Notch for Inside to Inside Hidden Connector	33490	12.75mm	41.76mm		\$2.10 ea.
45-7523	45	Corner Notch for Inside to Outside Hidden Connector	33530	12.75mm	41.76mm		\$2.10 ea.

80/20[®] Inc.

The Industrial Erector Set[®]

FOLLOW US



SOLUTIONS FOR ANY INDUSTRY:

**MACHINE TOOL
RETAIL SYSTEMS
COMPUTER RACKS
WORKSTATIONS**

**AUTOMATION
FURNITURE
CLEAN ROOMS
GUARDING**

**MATERIAL HANDLING
ROBOTICS
LINEAR MOTION
ELECTRONICS**

**MANUFACTURING
DISPLAYS / EXHIBITS
MEDICAL
AND MORE...**